

The PowerPak - Cylinder Package:

**An energy-efficient solution
for generating high forces.**

**Pressing Force: 0,6 - 100 t
Overall Stroke: 50 - 400 mm**



A first-rate handling solution provided by a world-class manufacturer...

ROSS is a global manufacturer of pneumatic valves, control systems, as well as safety-related and other products used in all key industries. Broad application know-how based on eight decades of experience in the air control trade have gained ROSS a reputation for excellence and quality worldwide. The PowerPak cylinder line combining the power of hydraulics and the flexible functionality of pneumatic control technology is just another example of the fact that we move forward and keep adjusting our offering to the ever-increasing demands in an industrial world focusing on powerful and cost efficient automation processes.

PowerPak — The pneumatic-hydraulic solution for forming and other applications (0.6 to 100 tons).

PowerPak is an air operated, highly powerful cylinder package featuring an integrated, closed hydraulic oil circuit. The power stroke starts automatically. The operation is similar to the functional characteristics of a double-acting pneumatic cylinder. Blending the benefits of hydraulics and pneumatics results in a first-rate handling solution.

Features of your PowerPak:

- Air pressure operated only
- Return stroke by pneumatic spring (improved control)
- High cycle frequency (dependant on stroke)
- Power stroke starts automatically
- Adjustable operating force
- Positive air-oil-separation
- Port for high pressure monitoring
- Multiple mounting options
- Units supplied ready-to-use
- Low noise, low maintenance
- Compact design

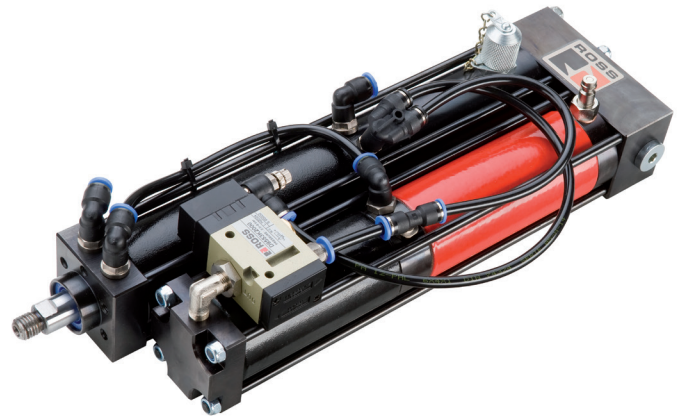

The comprehensive **ROSS Service** includes **Complete Systems** capabilities as well as the innovative **ROSS/FLEX®**-offering. We will be glad to provide you with details.

- Powerful
- Precise
- Reliable
- Economical



ROSS pneumatic valves provide extra reliability.

L-O-X®/EEZ-ON®-valves feature lock-out and fast exhaust capabilities as well as gradual pressure build-up in pneumatic systems. The valves can be padlocked in the "off"-position and are fully conforming to the safety requirements of **EN 1037** standard.



DM² Crossflow™ SERPAR® double valves with dynamic monitoring and memory capabilities. These valves in "double safe" design are conforming to safety categories 3 and 4 (**EN 954 / EN 13849**) and have BG approval.



Now available! Models with energy isolation features.

ROSS-safety-related products are well-proven and in full accordance with safety standards.

Ask ROSS for details about these and other products in the broad line of ROSS safety-related valves.

Typical applications include:



Forming

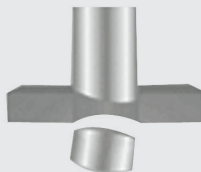

Punching

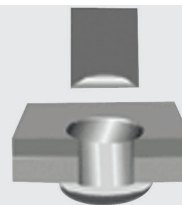

Riveting

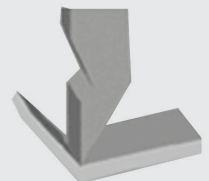

Bending

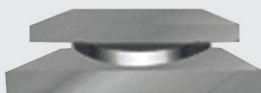

Pressing

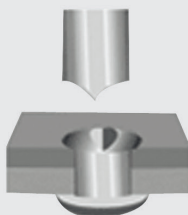

Squeezing

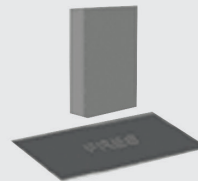

Coining

Joining

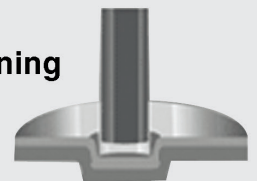

A System Comparison...



The shortcomings of hydraulic solutions:

- Dirty work environment (oil leakage)
- Slow movements and low cycle rates
- Large space requirements
- Constant force operating stroke
- High use of energy
- High noise level
- High capital cost



The shortcomings of pneumatic solutions:

- Low force
- Cumbersome construction
- High air consumption
- Non-linear force
- No adjustment of power stroke

Your Solution: Hydraulics + Pneumatics = PowerPak.

- Comprehensive product range (0.6 to 100 tons)
- No hydraulic power unit needed
- Low air consumption
- Power stroke starts automatically
- Fast cylinder movements
- Flexible stroke adjustment
- Cost-efficient
- Clean workplace
- Low noise levels
- Easy control adjustment
- Easily integrated into automation systems
- Low maintenance

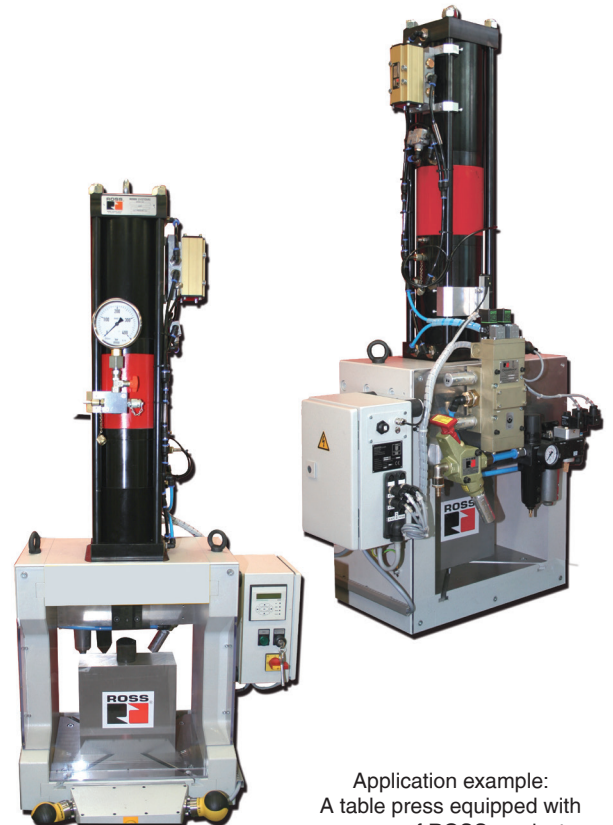

Application example:
A table press equipped with
an array of ROSS products.

The PowerPak Solution...

ROSS-PowerPak — An integrated cylinder system...

which combines both the powerful performance of hydraulics as well as the flexible qualities of rapidly moving pneumatics. The unit is operated like a conventional double-acting pneumatic cylinder. It features an integrated, closed oil volume and applies the power stroke automatically (see schematic below).

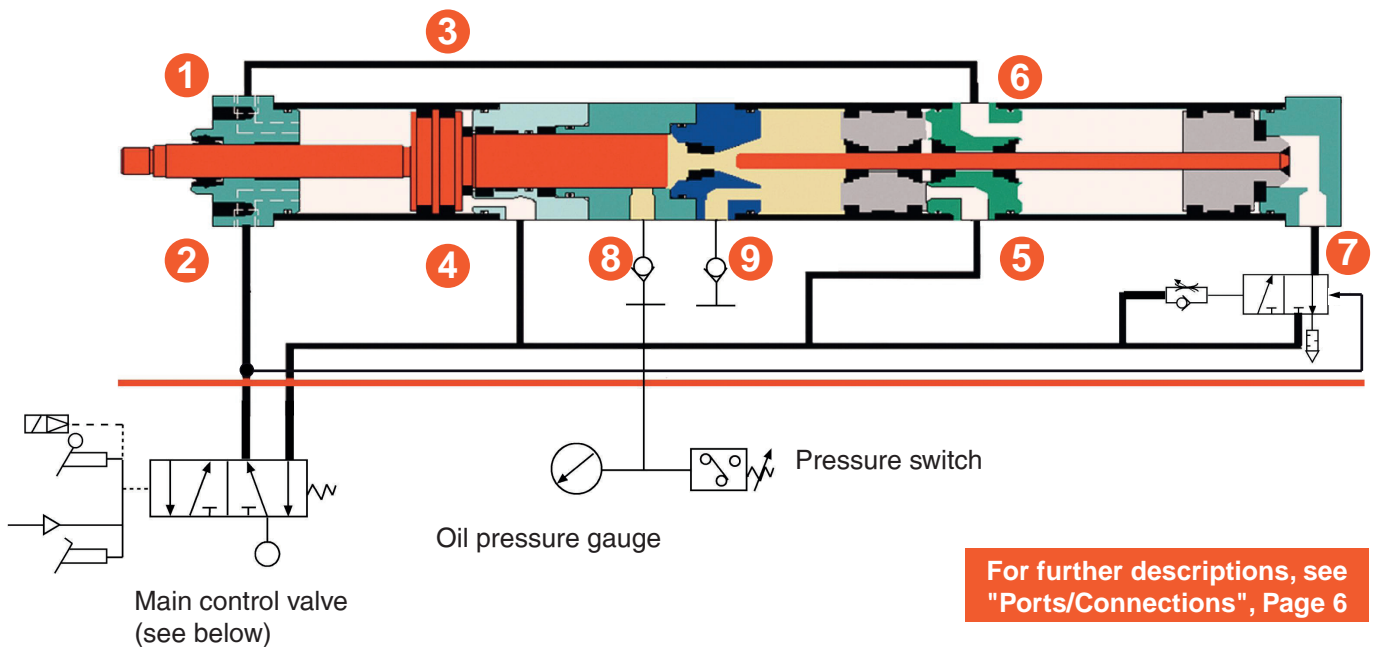

Main Control Valve

We recommend the use of ROSS 5/2-way double valves with CROSSMIRROR®-sensing (see Bulletin E383).



CROSSMIRROR® valves have been designed for the safe operation of pneumatically controlled cylinders, cylinder presses and other linear drives. As with all ROSS double valves, these products are of a control-reliable design.

Due to the base-mounting concept, valve exchange is easy and time-saving.

Innovative cylinder design. No springs involved.

The fact that the ROSS cylinders do not need spring mechanisms results in improved operational characteristics (control and reliability).

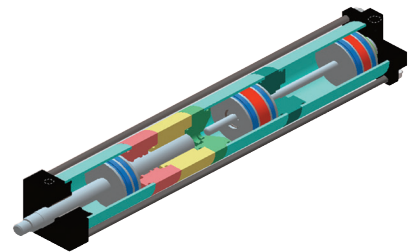

The full stroke of the ROSS-**PowerPak** covers three process sequences:
Rapid Approach, Power Stroke, Return Stroke.

Stroke Sequences of PowerPak-Cylinders

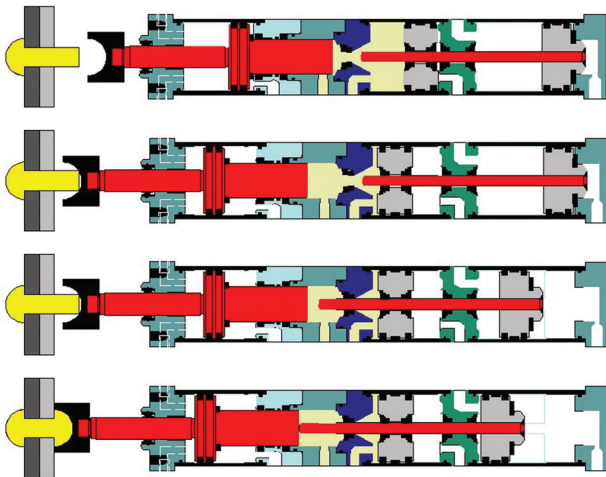

Functional Schematic (Example)

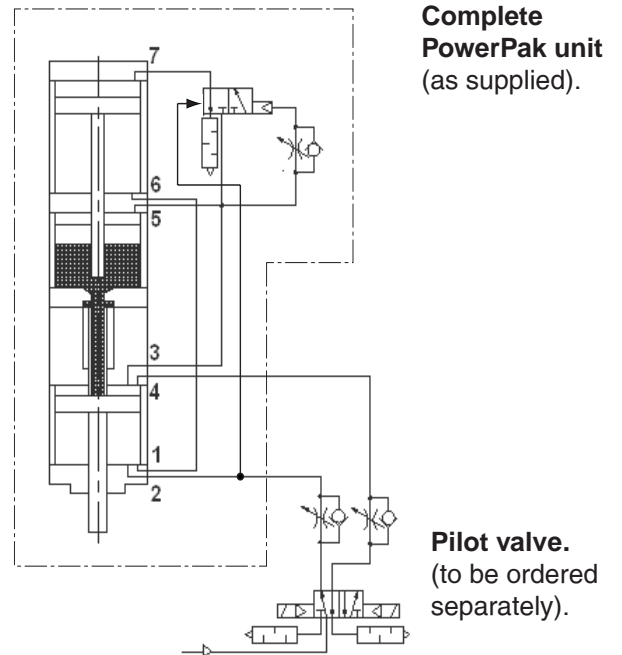

Operate with dried, filtered and lubricated compressed air only.

Ports / Connections

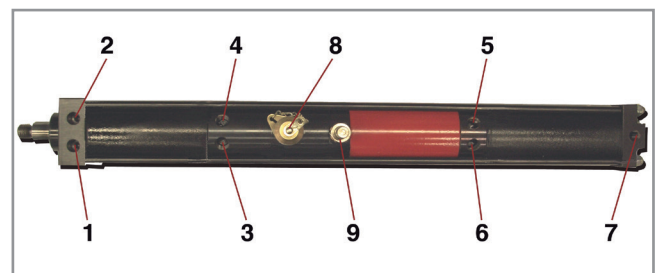

Rapid Approach Stroke / Low Force Stroke

As soon as the main control valve shifts, the rapid approach stroke is triggered with low force. The cylinder is now in its ready-to-work position.

Working Stroke / Power Stroke

The change-over valve is now piloted internally via the speed control valve, the power stroke starts automatically using the speed control valve to provide the change-over time adjustment from rapid approach to power stroke.

Return Stroke

The main control valve switches back to its starting position. The change-over valve is exhausted internally. Work piston and adjustment piston return to their starting positions at high speed.

Description:

1. Preconnected to port 6 for piston return stroke.
2. Pneumatic port for rapid retract stroke.
3. Preconnected to port 5 for piston rapid approach stroke.
4. Pneumatic port for piston rapid approach stroke.
5. (see 3.)
6. (see 1.)
7. Pneumatic port for power stroke.
8. Hydraulic pressure measuring port.
9. Oil filling connection.

The ROSS PowerPak Series — An Overview



"S" Series

Overall Stroke	50 to 400 mm
Power Stroke	6 to 60 mm
Power	0.6 to 100 t
Operating Pressure	2 to 10 bar. Full power at 6 or 10 bar operating pressure
Customized design	On request

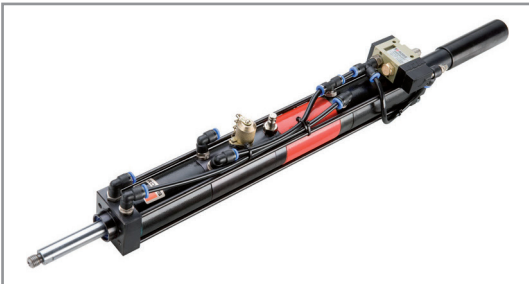

"SA" Series

Overall Stroke	50 to 400 mm
Power Stroke	6 to 60 mm
Power	0.5 to 100 t
Operating Pressure	2 to 10 bar. Full power at 6 or 10 bar operating pressure

"SA" = "S" Series featuring power stroke limitation

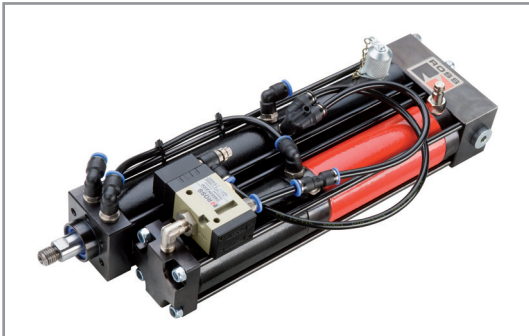

"SK" Series

Overall Stroke	100 to 400 mm
Power Stroke	5 to 20 mm
Power	0.5 to 50 t
Operating Pressure	2 to 10 bar. Full power at 6 or 10 bar operating pressure
Customized design	On request

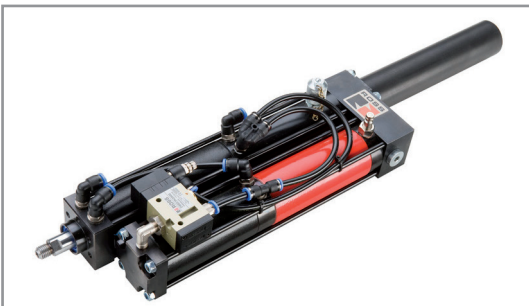

"SKA" Series

Overall Stroke	100 to 400 mm
Power Stroke	5 to 20 mm
Power	0.5 to 50 t
Operating Pressure	2 to 10 bar. Full power at 6 or 10 bar operating pressure

"SKA" = "SK" Series feat. power stroke limitation

PowerPak – "S" Series

6 bar – 0.6 to 100 t

SPECIFICATIONS

Overall Stroke: 50 to 400 mm

Power Stroke: 6 to 60 mm

Power: 0.6 to 100 t

Operating Pressure: 2 to 6 bar. Maximum force is achieved at 6 bar operating pressure.

Customized Design: on request.

Power Stroke Limitation: on request.

Model Number (Example)

RE 06 S01 - 100 - 10

Power Stroke

Overall Stroke

Series

Max. Operating Pressure

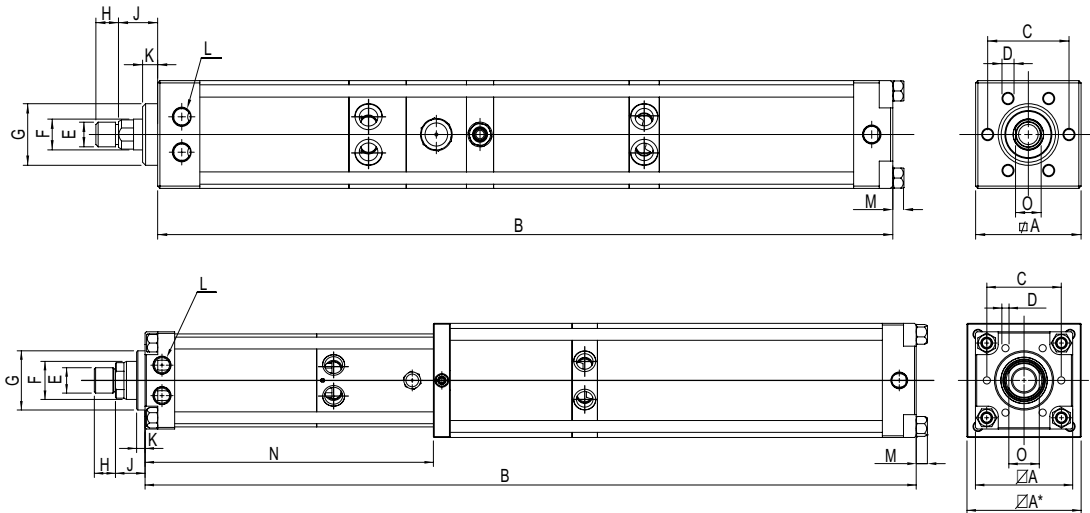

Type	Overall Stroke mm	Power Stroke mm	max. Power (daN)	Power, Fast Str. (daN)	Power, Return Str. (daN)	Dimensions mm													
						A	A*	B	C	D (6x)	E	F	G	H	J	K	L	M	N
RE 06 S01	50	6	670	55	58	50		437	40	M6x12	M12x1,5	16	30	12	24	10	G 1/8		14
RE 06 S01	50	12	600	55	58	60		474	49	M6x12	M12x1,5	16	30	12	24	10	G 1/8		14
RE 06 S01	100	6	670	55	58	50		577	40	M6x12	M12x1,5	16	30	12	24	10	G 1/8		14
RE 06 S01	100	12	600	55	58	60		800	40	M6x12	M12x1,5	16	30	12	24	10	G 1/8		14
RE 06 S02	50	6	1050	83	97	60		498	40	M6x12	M12x1,5	16	30	12	24	10	G 1/8		14
RE 06 S02	50	12	1070	83	97	70		498	40	M6x12	M12x1,5	16	30	12	24	10	G 1/8		14
RE 06 S02	100	6	1050	83	97	60		644	40	M6x12	M12x1,5	16	30	12	24	10	G 1/8		14
RE 06 S02	100	12	1070	83	97	70		628	40	M6x12	M12x1,5	16	30	12	24	10	G 1/8		14
RE 06 S02	150	6	1050	83	97	60		790	40	M6x12	M12x1,5	16	30	12	24	10	G 1/8		14
RE 06 S02	150	12	1070	83	97	70		758	40	M6x12	M12x1,5	16	30	12	24	10	G 1/8		14
RE 06 S03	50	6	1810	144	154	70		488	54	M8x12	M16x1,5	20	40	15	26	10	G 1/4		17
RE 06 S03	50	12	1660	144	154	70	85	530	54	M8x12	M16x1,5	20	40	15	26	10	G 1/4	205	17
RE 06 S03	70	25	1660	144	154	70	85	663	54	M8x12	M16x1,5	20	40	15	26	10	G 1/4	245	17
RE 06 S03	100	6	1810	144	154	70		620	54	M8x12	M16x1,5	20	40	15	26	10	G 1/4		17
RE 06 S03	100	12	1660	144	154	70	85	652	54	M8x12	M16x1,5	20	40	15	26	10	G 1/4	305	17
RE 06 S03	100	25	1660	144	154	70	85	734	54	M8x12	M16x1,5	20	40	15	26	10	G 1/4	305	17
RE 06 S03	100	40	2000	144	154	70	110	760	54	M8x12	M16x1,5	20	40	15	26	10	G 1/4	305	17
RE 06 S03	150	6	1810	144	154	70		752	54	M8x12	M16x1,5	20	40	15	26	10	G 1/4		17
RE 06 S03	150	12	1660	144	154	70	85	774	54	M8x12	M16x1,5	20	40	15	26	10	G 1/4	405	17
RE 06 S03	150	25	1660	144	154	70	85	856	54	M8x12	M16x1,5	20	40	15	26	10	G 1/4	405	17
RE 06 S03	150	40	2000	144	154	70	110	872	54	M8x12	M16x1,5	20	40	15	26	10	G 1/4	405	17
RE 06 S03	150	50	2000	144	154	70	110	916	54	M8x12	M16x1,5	20	40	15	26	10	G 1/4	405	17
RE 06 S03	200	6	1810	144	154	70		884	54	M8x12	M16x1,5	20	40	15	26	10	G 1/4		17
RE 06 S03	200	12	1660	144	154	70	85	896	54	M8x12	M16x1,5	20	40	15	26	10	G 1/4	505	17
RE 06 S03	200	25	1660	144	154	70	85	979	54	M8x12	M16x1,5	20	40	15	26	10	G 1/4	505	17
RE 06 S03	200	40	2000	144	154	70	110	984	54	M8x12	M16x1,5	20	40	15	26	10	G 1/4	505	17
RE 06 S03	200	60	2000	144	154	70	110	1071	54	M8x12	M16x1,5	20	40	15	26	10	G 1/4	505	17
RE 06 S03	250	60	2000	144	154	70	110	1183	54	M8x12	M16x1,5	20	40	15	26	10	G 1/4	605	17

Max. power indication ± 5%

PowerPak – "S" Series

6 bar – 0.6 to 100 t

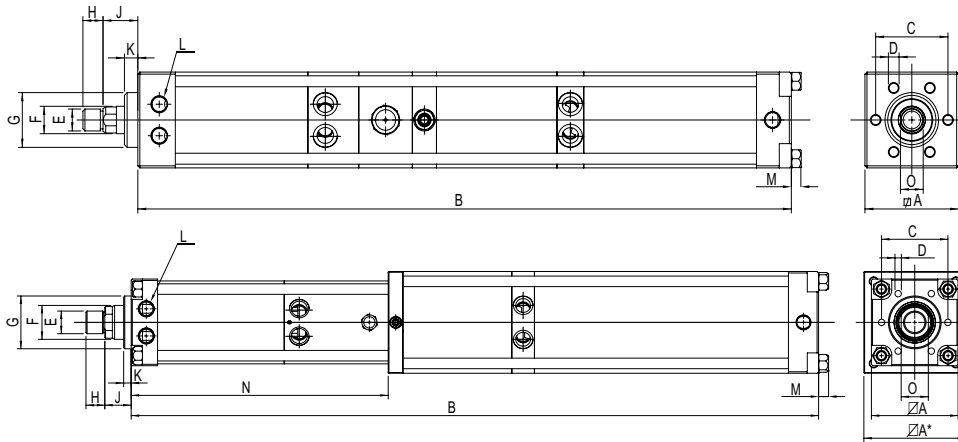

Type	Overall Stroke mm	Power Stroke mm	max. Power (daN)	Power, Fast Str. (daN)	Power, Return Str. (daN)	Dimensions mm														
						A	A*	B	C	D (6x)	E	F	G	H	J	K	L	M	N	O
RE 06 S04	50	6	3330	187	200	85		563	64	M8x15	M22x2	30	50	20	28,5	10	G 3/8			24
RE 06 S04	50	12	3330	187	200	85		641	64	M8x15	M22x2	30	50	20	28,5	10	G 3/8			24
RE 06 S04	70	25	4070	187	200	90	110	767	64	M8x15	M22x2	30	50	20	28,5	10	G 3/8		251	24
RE 06 S04	100	6	3330	187	200	85		709	64	M8x15	M22x2	30	50	20	28,5	10	G 3/8			24
RE 06 S04	100	12	3330	187	200	85		787	64	M8x15	M22x2	30	50	20	28,5	10	G 3/8			24
RE 06 S04	100	25	4070	187	200	90	110	843	64	M8x15	M22x2	30	50	20	28,5	10	G 3/8		311	24
RE 06 S04	150	6	3330	187	200	85		855	64	M8x15	M22x2	30	50	20	28,5	10	G 3/8			24
RE 06 S04	150	12	3330	187	200	85		933	64	M8x15	M22x2	30	50	20	28,5	10	G 3/8			24
RE 06 S04	150	25	4070	187	200	90	110	969	64	M8x15	M22x2	30	50	20	28,5	10	G 3/8		411	24
RE 06 S04	150	40	3600	187	200	90	135	926	64	M8x15	M22x2	30	50	20	28,5	10	G 3/8	13	411	24
RE 06 S04	200	6	3330	187	200	85		1001	64	M8x15	M22x2	30	50	20	28,5	10	G 3/8			24
RE 06 S04	200	12	3330	187	200	85		1079	64	M8x15	M22x2	30	50	20	28,5	10	G 3/8			24
RE 06 S04	200	25	4070	187	200	90	110	1095	64	M8x15	M22x2	30	50	20	28,5	10	G 3/8		511	24
RE 06 S04	200	40	3600	187	200	90	135	1042	64	M8x15	M22x2	30	50	20	28,5	10	G 3/8	13	511	24
RE 06 S04	200	50	3600	187	200	90	135	1093	64	M8x15	M22x2	30	50	20	28,5	10	G 3/8	13	511	24
RE 06 S04	250	12	3330	187	200	85		1225	64	M8x15	M22x2	30	50	20	28,5	10	G 3/8			24
RE 06 S04	250	25	4070	187	200	90	110	1221	64	M8x15	M22x2	30	50	20	28,5	10	G 3/8		611	24
RE 06 S04	250	40	3600	187	200	90	135	1158	64	M8x15	M22x2	30	50	20	28,5	10	G 3/8	13	611	24
RE 06 S04	300	60	3600	187	200	90	135	1377	64	M8x15	M22x2	30	50	20	28,5	10	G 3/8	13	711	24
RE 06 S04	400	60	3600	187	200	90	135	1611	64	M8x15	M22x2	30	50	20	28,5	10	G 3/8	13	911	24
RE 06 S05	50	6	7820	324	344	110		651	88	M10x16	M30x2	45	70	25	35	10	G 1/2			36
RE 06 S05	50	12	7820	324	344	110		755	88	M10x16	M30x2	45	70	25	35	10	G 1/2			36
RE 06 S05	50	20	6910	324	344	115	135	731	88	M10x16	M30x2	45	70	25	35	10	G 1/2	13	241	36
RE 06 S05	100	6	7820	324	344	110		801	88	M10x16	M30x2	45	70	25	35	10	G 1/2			36
RE 06 S05	100	12	7820	324	344	110		905	88	M10x16	M30x2	45	70	25	35	10	G 1/2			36
RE 06 S05	100	25	6910	324	344	115	135	912	88	M10x16	M30x2	45	70	25	35	10	G 1/2	13	341	36
RE 06 S05	100	40	7230	324	344	115	170	943	88	M10x16	M30x2	45	70	25	35	10	G 1/2	17	341	36
RE 06 S05	150	6	7820	324	344	110		951	88	M10x16	M30x2	45	70	25	35	10	G 1/2			36
RE 06 S05	150	12	7820	324	344	110		1055	88	M10x16	M30x2	45	70	25	35	10	G 1/2			36
RE 06 S05	150	25	6910	324	344	115	135	1044	88	M10x16	M30x2	45	70	25	35	10	G 1/2	13	441	36
RE 06 S05	150	40	7230	324	344	115	170	1063	88	M10x16	M30x2	45	70	25	35	10	G 1/2	17	441	36
RE 06 S05	200	6	7820	324	344	110		1101	88	M10x16	M30x2	45	70	25	35	10	G 1/2			36
RE 06 S05	200	12	7820	324	344	110		1205	88	M10x16	M30x2	45	70	25	35	10	G 1/2			36
RE 06 S05	200	25	6910	324	344	115	135	1176	88	M10x16	M30x2	45	70	25	35	10	G 1/2	13	541	36
RE 06 S05	200	40	7230	324	344	115	170	1183	88	M10x16	M30x2	45	70	25	35	10	G 1/2	17	541	36
RE 06 S05	200	60	7230	324	344	115	170	1308	88	M10x16	M30x2	45	70	25	35	10	G 1/2	17	541	36
RE 06 S05	250	12	7820	324	344	110		1355	88	M10x16	M30x2	45	70	25	35	10	G 1/2			36
RE 06 S05	250	25	6910	324	344	115	135	1308	88	M10x16	M30x2	45	70	25	35	10	G 1/2	13	641	36
RE 06 S05	250	40	7230	324	344	115	170	1303	88	M10x16	M30x2	45	70	25	35	10	G 1/2	17	641	36
RE 06 S05	300	60	7230	324	344	115	170	1548	88	M10x16	M30x2	45	70	25	35	10	G 1/2	17	741	36
RE 06 S05	400	60	7230	324	344	115	170	1788	88	M10x16	M30x2	45	70	25	35	10	G 1/2	17	941	36

Max. power indication ± 5%

PowerPak – "S" Series

6 bar – 0.6 to 100 t

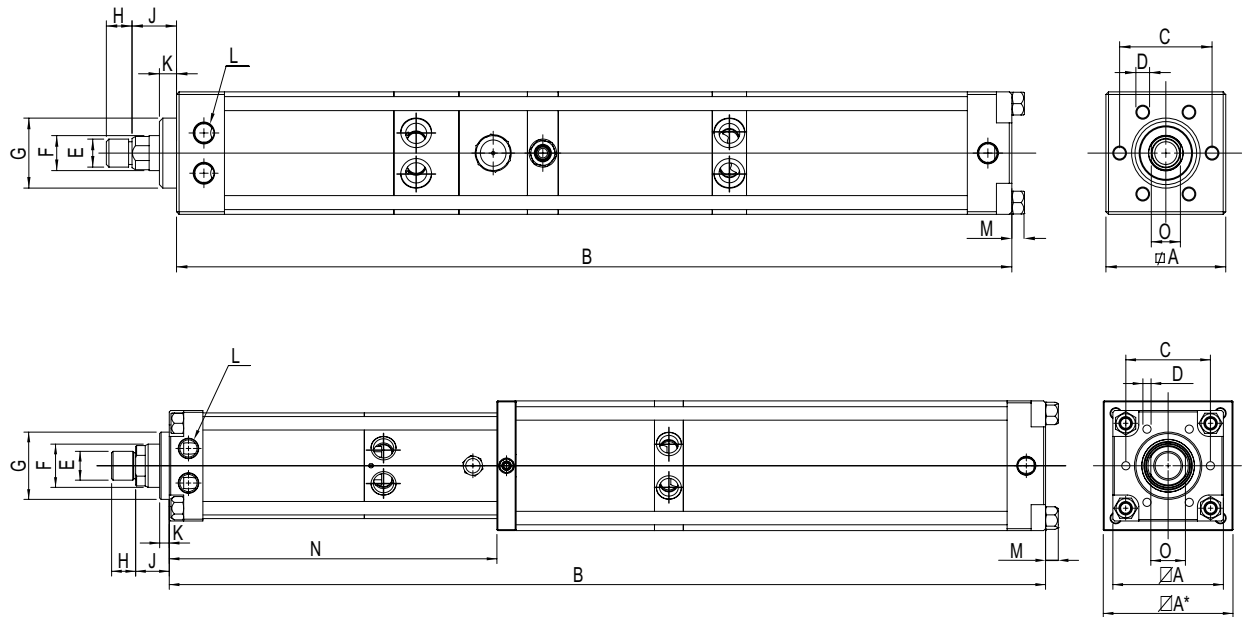

Type	Overall Stroke mm	Power Stroke mm	max. Power (daN)	Power, Fast Str. (daN)	Power, Return Str. (daN)	Dimensions mm														
						A	A''	B	C	D (6x)	E	F	G	H	J	K	L	M	N	O
RE 06 S06	50	6	13380	460	565	135		693	100	M16x25	M30x2	50	75	25	36	15	G 1/2			41
RE 06 S06	50	12	13380	460	565	135		807	100	M16x25	M30x2	50	75	25	36	15	G 1/2			41
RE 06 S06	100	6	13380	460	565	135		855	100	M16x25	M30x2	50	75	25	36	15	G 1/2			41
RE 06 S06	100	12	13380	460	565	135		970	100	M16x25	M30x2	50	75	25	36	15	G 1/2			41
RE 06 S06	100	25	14000	460	565	140	170	1054	100	M16x25	M30x2	50	75	25	36	15	G 1/2	17	353	41
RE 06 S06	150	6	13380	460	565	135		1018	100	M16x25	M30x2	50	75	25	36	15	G 1/2			41
RE 06 S06	150	12	13380	460	565	135		1133	100	M16x25	M30x2	50	75	25	36	15	G 1/2			41
RE 06 S06	150	25	14000	460	565	140	170	1194	100	M16x25	M30x2	50	75	25	36	15	G 1/2	17	453	41
RE 06 S06	150	40	13380	460	565	140	200	1296	100	M16x25	M30x2	50	75	25	36	15	G 1/2	17	453	41
RE 06 S06	200	6	13380	460	565	135		1181	100	M16x25	M30x2	50	75	25	36	15	G 1/2			41
RE 06 S06	200	12	13380	460	565	135		1296	100	M16x25	M30x2	50	75	25	36	15	G 1/2			41
RE 06 S06	200	25	14000	460	565	140	170	1334	100	M16x25	M30x2	50	75	25	36	15	G 1/2	17	553	41
RE 06 S06	200	40	13380	460	565	140	200	1399	100	M16x25	M30x2	50	75	25	36	15	G 1/2	17	553	41
RE 06 S06	250	12	13380	460	565	135		1459	100	M16x25	M30x2	50	75	25	36	15	G 1/2			41
RE 06 S06	250	25	14000	460	565	140	170	1474	100	M16x25	M30x2	50	75	25	36	15	G 1/2	17	653	41
RE 06 S06	250	40	13380	460	565	140	200	1529	100	M16x25	M30x2	50	75	25	36	15	G 1/2	17	653	41
RE 06 S06	300	40	13380	460	565	140	200	1659	100	M16x25	M30x2	50	75	25	36	15	G 1/2	17	753	41
RE 06 S07	50	6	28300	675	970	170		803	132	M20x30	M39x2	56	100	35	47	18	G 3/4	23		50
RE 06 S07	100	6	28300	675	970	170		981	132	M20x30	M39x2	56	100	35	47	18	G 3/4	23		50
RE 06 S07	100	12	28300	675	970	170		1131	132	M20x30	M39x2	56	100	35	47	18	G 3/4	23		50
RE 06 S07	100	20	30650	675	970	190	270	998	132	M20x30	M39x2	56	100	35	47	18	G 3/4	17	361	50
RE 06 S07	150	6	28300	675	970	170		1159	132	M20x30	M39x2	56	100	35	47	18	G 3/4	23		50
RE 06 S07	150	12	28300	675	970	170		1309	132	M20x30	M39x2	56	100	35	47	18	G 3/4	23		50
RE 06 S07	150	25	30650	675	970	190	270	1185	132	M20x30	M39x2	56	100	35	47	18	G 3/4	17	461	50
RE 06 S07	200	6	28300	675	970	170		1337	132	M20x30	M39x2	56	100	35	47	18	G 3/4	23		50
RE 06 S07	200	12	28300	675	970	170		1487	132	M20x30	M39x2	56	100	35	47	18	G 3/4	23		50
RE 06 S07	200	25	30650	675	970	190	270	1317	132	M20x30	M39x2	56	100	35	47	18	G 3/4	17	561	50
RE 06 S07	200	35	30650	675	970	190	270	1428	132	M20x30	M39x2	56	100	35	47	18	G 3/4	17	561	50
RE 06 S07	250	12	28300	675	970	170		1665	132	M20x30	M39x2	56	100	35	47	18	G 3/4	23		50
RE 06 S07	300	25	30650	675	970	190	270	1581	132	M20x30	M39x2	56	100	35	47	18	G 3/4	17	761	50
RE 06 S07	300	40	30650	675	970	190	270	1748	132	M20x30	M39x2	56	100	35	47	18	G 3/4	17	761	50
RE 06 S07	400	40	30650	675	970	190	270	2012	132	M20x30	M39x2	56	100	35	47	18	G 3/4	17	961	50

Max. power indication ± 5%

PowerPak – "S" Series

6 bar – 0.6 to 100 t

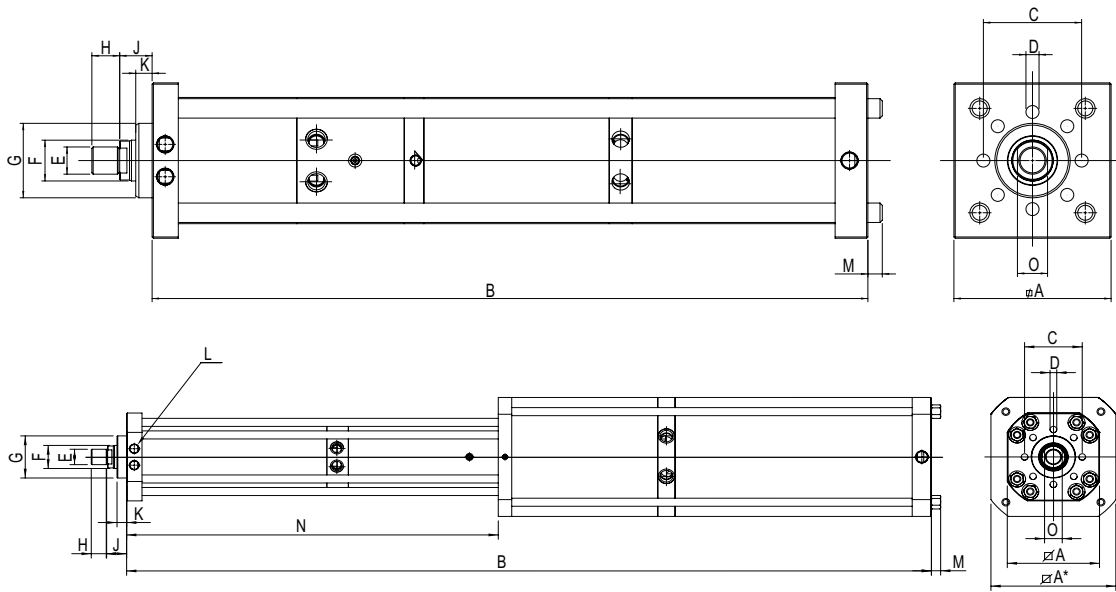

Type	Overall Stroke mm	Power Stroke mm	max. Power (daN)	Power, Fast Str. (daN)	Power, Return Str. (daN)	Dimensions mm															
						A	A*	B	C	D (8x)	E	F	G	H	J	K	L	M	N	O	
RE 06 S08	70	6	45900	725	1225	200		957	150	M20x30	M42x2	63	115	40	52	25	G 3/4	31	55		
RE 06 S08	100	6	45900	725	1225	200		1057	150	M20x30	M42x2	63	115	40	52	25	G 3/4	31	55		
RE 06 S08	100	12	47600	725	1225	220	270	1026	150	M20x30	M42x2	63	115	40	52	25	G 3/4	17	367	55	
RE 06 S08	150	6	45900	725	1225	200		1271	150	M20x30	M42x2	63	115	40	52	25	G 3/4	31	55		
RE 06 S08	200	10	45900	725	1225	200		1597	150	M20x30	M42x2	63	115	40	52	25	G 3/4	31	55		
RE 06 S08	200	20	47600	725	1225	220	270	1465	150	M20x30	M42x2	63	115	40	52	25	G 3/4	17	567	55	
RE 06 S08	250	10	45900	725	1225	200		1793	150	M20x30	M42x2	63	115	40	52	25	G 3/4	31	55		
RE 06 S08	300	20	47600	725	1225	220	270	1765	150	M20x30	M42x2	63	115	40	52	25	G 3/4	17	767	55	
RE 06 S08	300	30	47600	725	1225	200		325	1693	150	M20x30	M42x2	63	115	40	52	25	G 3/4	21	767	55
RE 06 S08	400	40	47600	725	1225	200		325	2084	150	M20x30	M42x2	63	115	40	52	25	G 3/4	21	967	55

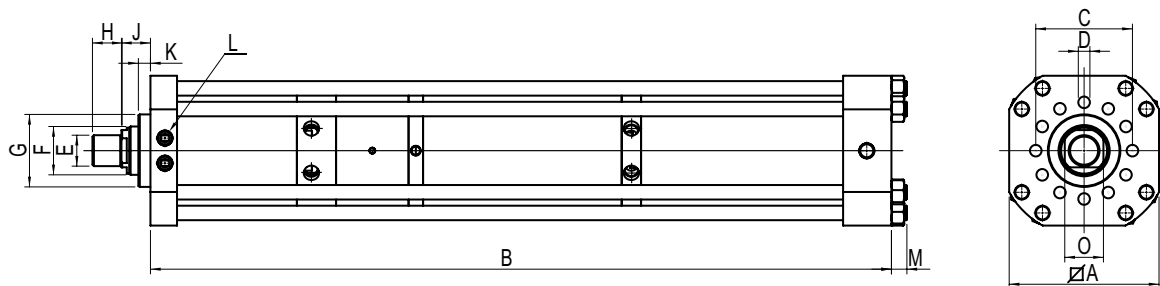

Type	Overall Stroke mm	Power Stroke mm	max. Power (daN)	Power, Fast Str. (daN)	Power, Return Str. (daN)	Dimensions mm														
						A	A*	B	C	D (12x)	E	F	G	H	J	K	L	M	N	O
RE 06 S09	100	10	72700	1300	2250	325		1329	200	M24x40	M64x2	100	150	60	60	25	G 1	31	85	
RE 06 S09	150	10	72700	1300	2250	325		1533	200	M24x40	M64x2	100	150	60	60	25	G 1	31	85	
RE 06 S09	200	13	72700	1300	2250	325		1809	200	M24x40	M64x2	100	150	60	60	25	G 1	31	85	
RE 06 S09	250	12	72700	1300	2250	325		2013	200	M24x40	M64x2	100	150	60	60	25	G 1	31	85	
RE 06 S09	300	16	72700	1300	2250	325		2288	200	M24x40	M64x2	100	150	60	60	25	G 1	31	85	
RE 06 S10	100	8	98500	1300	2250	325		1329	200	M24x40	M64x2	100	150	60	60	25	G 1	31	85	
RE 06 S10	150	8	98500	1300	2250	325		1533	200	M24x40	M64x2	100	150	60	60	25	G 1	31	85	
RE 06 S10	200	10	98500	1300	2250	325		1809	200	M24x40	M64x2	100	150	60	60	25	G 1	31	85	
RE 06 S10	250	10	98500	1300	2250	325		2013	200	M24x40	M64x2	100	150	60	60	25	G 1	31	85	
RE 06 S10	300	12	98500	1300	2250	325		2288	200	M24x40	M64x2	100	150	60	60	25	G 1	31	85	

Max. power indication ± 5%

PowerPak – "SK" Series

6 bar – 0.6 to 50 t

SPECIFICATIONS

Overall Stroke: 50 to 400 mm

Power Stroke: 5 to 40 mm

Power: 0.6 to 50 t

Operating Pressure: 2 to 6 bar. Maximum force is achieved at 6 bar operating pressure.

Customized Design: on request

Power Stroke Limitation: on request.

Model Number (Example)

RE 06 SK01 - 100 - 10

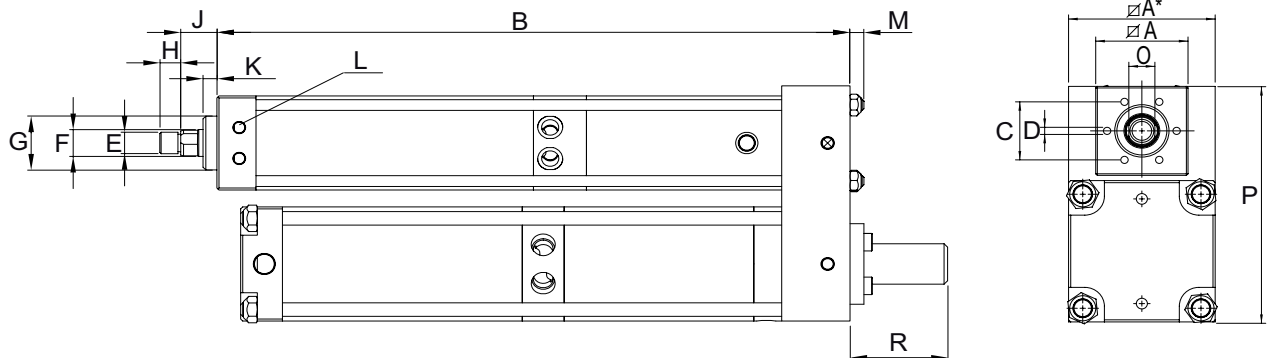
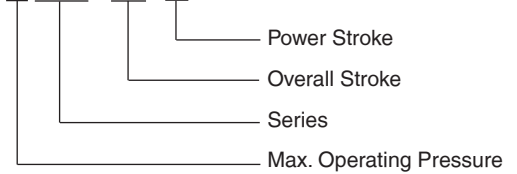

Type	Overall Stroke mm	Power Stroke mm	max. Power (daN)	Power, Fast Str. (daN)	Power, Return Str. (daN)	Dimensions mm															
						A	A*	B	C	D (6x)	E	F	G	H	J	K	L	M	P	O	R
RE 06 SK01	100	5	670	55	58	50		331	40	M6x12	M12x1,5	16	30	12	24	10	G 1/8	105	14		
RE 06 SK01	100	10	670	55	58	50		353	40	M6x12	M12x1,5	16	30	12	24	10	G 1/8	105	14		
RE 06 SK01	100	15	600	55	58	50	60	335	40	M6x12	M12x1,5	16	30	12	24	10	G 1/8	115	14		
RE 06 SK01	150	10	670	55	58	50		421	40	M6x12	M12x1,5	16	30	12	24	10	G 1/8	105	14		
RE 06 SK01	100	15	600	55	58	50	60	421	40	M6x12	M12x1,5	16	30	12	24	10	G 1/8	115	14		
RE 06 SK02	100	5	1050	83	97	60		389	40	M6x12	M12x1,5	16	30	12	24	10	G 1/8	125	14		
RE 06 SK02	100	10	1050	83	97	60		372	40	M6x12	M12x1,5	16	30	12	24	10	G 1/8	125	14		
RE 06 SK02	100	15	1070	83	97	60	70	388	40	M6x12	M12x1,5	16	30	12	24	10	G 1/8	134	14		
RE 06 SK02	150	10	1050	83	97	60		442	40	M6x12	M12x1,5	16	30	12	24	10	G 1/8	125	14		
RE 06 SK02	150	15	1070	83	97	60	70	442	40	M6x12	M12x1,5	16	30	12	24	10	G 1/8	134	14		
RE 06 SK03	100	4	1810	144	154	70		349	54	M8x12	M16x1,5	20	40	15	26	10	G 1/4	145	17		
RE 06 SK03	100	10	1660	144	154	70	85	402	54	M8x12	M16x1,5	20	40	15	26	10	G 1/4	160	17		
RE 06 SK03	100	15	2000	144	154	70	110	414	54	M8x12	M16x1,5	20	40	15	26	10	G 1/4	185	17		
RE 06 SK03	150	10	1660	144	154	70	85	449	54	M8x12	M16x1,5	20	40	15	26	10	G 1/4	160	17		
RE 06 SK03	150	15	2000	144	154	70	110	402	54	M8x12	M16x1,5	20	40	15	26	10	G 1/4	185	17		
RE 06 SK03	200	10	1660	144	154	70	85	549	54	M8x12	M16x1,5	20	40	15	26	10	G 1/4	160	17		
RE 06 SK03	200	15	2000	144	154	70	110	549	54	M8x12	M16x1,5	20	40	15	26	10	G 1/4	185	17		
RE 06 SK04	100	5	3330	187	200	85		454	64	M8x15	M22x2	30	50	20	28,5	10	G 3/8	175	24		
RE 06 SK04	100	10	4070	187	200	85	110	488	64	M8x15	M22x2	30	50	20	28,5	10	G 3/8	200	24		
RE 06 SK04	100	20	3600	187	200	85	135	450	64	M8x15	M22x2	30	50	20	28,5	10	G 3/8	13	225	24	51
RE 06 SK04	150	5	3330	187	200	85		500	64	M8x15	M22x2	30	50	20	28,5	10	G 3/8	175	24		
RE 06 SK04	150	10	4070	187	200	85	110	514	64	M8x15	M22x2	30	50	20	28,5	10	G 3/8	200	24		
RE 06 SK04	150	20	3600	187	200	85	135	470	64	M8x15	M22x2	30	50	20	28,5	10	G 3/8	13	225	24	51
RE 06 SK04	200	5	3330	187	200	85		560	64	M8x15	M22x2	30	50	20	28,5	10	G 3/8	175	24		
RE 06 SK04	200	10	4070	187	200	85	110	560	64	M8x15	M22x2	30	50	20	28,5	10	G 3/8	200	24		
RE 06 SK04	200	20	3600	187	200	85	135	560	64	M8x15	M22x2	30	50	20	28,5	10	G 3/8	13	225	24	51

Max. power indication ± 5%

PowerPak – "SK" Series

6 bar – 0.6 to 50 t

Type	Overall Stroke mm	Power Stroke mm	max. Power (daN)	Power, Fast Str. (daN)	Power, Return Str. (daN)	Dimensions mm															
						A	A*	B	C	D (6x)	E	F	G	H	J	K	L	M	P	O	R
RE 06 SK05	100	5	7820	324	344	110		531	88	M10x16	M30x2	45	70	25	35	10	G 1/2		225	36	
RE 06 SK05	100	10	6910	324	344	110	135	526	88	M10x16	M30x2	45	70	25	35	10	G 1/2	13	250	36	
RE 06 SK05	100	20	7230	324	344	110	170	540	88	M10x16	M30x2	45	70	25	35	10	G 1/2	17	285	36	63
RE 06 SK05	150	5	7820	324	344	110		581	88	M10x16	M30x2	45	70	25	35	10	G 1/2		225	36	
RE 06 SK05	150	10	6910	324	344	110	135	558	88	M10x16	M30x2	45	70	25	35	10	G 1/2	13	250	36	
RE 06 SK05	150	20	7230	324	344	110	170	560	88	M10x16	M30x2	45	70	25	35	10	G 1/2	17	285	36	63
RE 06 SK05	200	5	7820	324	344	110		631	88	M10x16	M30x2	45	70	25	35	10	G 1/2		225	36	
RE 06 SK05	200	10	6910	324	344	110	135	599	88	M10x16	M30x2	45	70	25	35	10	G 1/2	13	250	36	
RE 06 SK05	200	20	7230	324	344	110	170	599	88	M10x16	M30x2	45	70	25	35	10	G 1/2	17	285	36	63
RE 06 SK05	250	10	6910	324	344	110	135	699	88	M10x16	M30x2	45	70	25	35	10	G 1/2	13	250	36	
RE 06 SK05	250	20	7230	324	344	110	170	699	88	M10x16	M30x2	45	70	25	35	10	G 1/2	17	285	36	63
RE 06 SK06	100	5	13380	460	565	135		585	100	M16x25	M30x2	50	75	25	36	15	G 1/2		275	41	
RE 06 SK06	100	10	14000	460	565	135	170	591	100	M16x25	M30x2	50	75	25	36	15	G 1/2	17	310	41	53
RE 06 SK06	100	20	13380	460	565	135	200	558	100	M16x25	M30x2	50	75	25	36	15	G 1/2	17	336	41	
RE 06 SK06	150	5	13380	460	565	135		648	100	M16x25	M30x2	50	75	25	36	15	G 1/2		275	41	
RE 06 SK06	150	10	14000	460	565	135	170	631	100	M16x25	M30x2	50	75	25	36	15	G 1/2	17	310	41	53
RE 06 SK06	150	20	13380	460	565	135	200	572	100	M16x25	M30x2	50	75	25	36	15	G 1/2	17	336	41	
RE 06 SK06	200	5	13380	460	565	135		711	100	M16x25	M30x2	50	75	25	36	15	G 1/2		275	41	
RE 06 SK06	200	10	14000	460	565	135	170	671	100	M16x25	M30x2	50	75	25	36	15	G 1/2	17	310	41	53
RE 06 SK06	200	20	13380	460	565	135	200	621	100	M16x25	M30x2	50	75	25	36	15	G 1/2	17	336	41	
RE 06 SK06	250	5	13380	460	565	135		774	100	M16x25	M30x2	50	75	25	36	15	G 1/2		275	41	
RE 06 SK06	250	10	14000	460	565	135	170	721	100	M16x25	M30x2	50	75	25	36	15	G 1/2	17	310	41	53
RE 06 SK06	250	20	13380	460	565	135	200	721	100	M16x25	M30x2	50	75	25	36	15	G 1/2		336	41	
RE 06 SK07	100	10	30650	675	970	170	270	609	132	M20x30	M39x2	56	100	35	47	18	G 3/4	17	446	50	42
RE 06 SK07	150	10	30650	675	970	170	270	641	132	M20x30	M39x2	56	100	35	47	18	G 3/4	17	446	50	42
RE 06 SK07	150	20	30650	675	970	170	270	752	132	M20x30	M39x2	56	100	35	47	18	G 3/4	17	446	50	152
RE 06 SK07	200	10	30650	675	970	170	270	673	132	M20x30	M39x2	56	100	35	47	18	G 3/4	17	446	50	42
RE 06 SK07	200	20	30650	675	970	170	270	784	132	M20x30	M39x2	56	100	35	47	18	G 3/4	17	446	50	152
RE 06 SK07	300	20	30650	675	970	170	270	849	132	M20x30	M39x2	56	100	35	47	18	G 3/4	17	446	50	152
RE 06 SK07	400	20	30650	675	970	170	270	1039	132	M20x30	M39x2	56	100	35	47	18	G 3/4	17	446	50	42

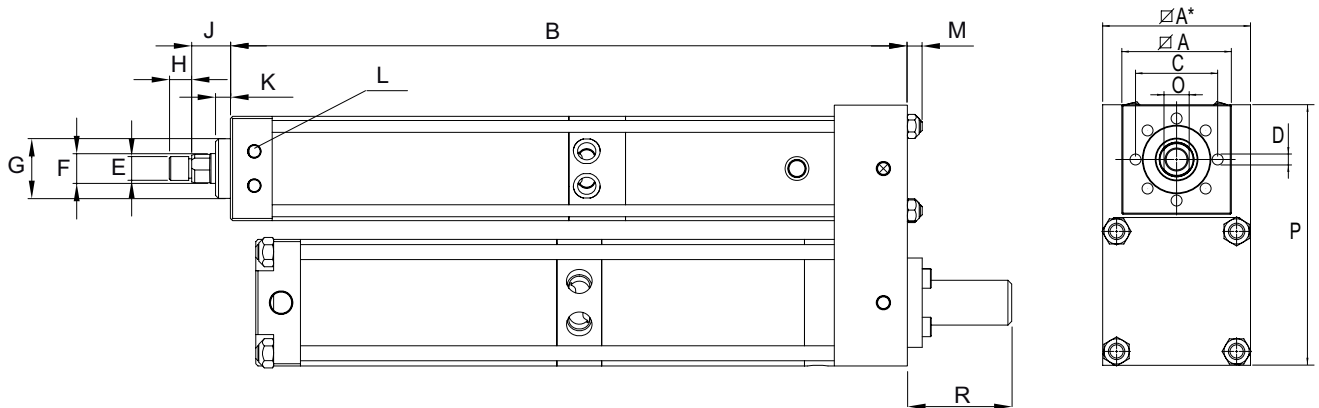

Type	Overall Stroke mm	Power Stroke mm	max. Power (daN)	Power, Fast Str. (daN)	Power, Return Str. (daN)	Dimensions mm															
						A	A*	B	C	D (8x)	E	F	G	H	J	K	L	M	P	O	R
RE 06 SK08	100	10	47600	725	1225	200	270	727	150	M20x30	M42x2	63	115	40	52	25	G 3/4	23	476	55	85
RE 06 SK08	100	20	47600	725	1225	200	325	769	150	M20x30	M42x2	63	115	40	52	25	G 3/4	23	534	55	154
RE 06 SK08	200	10	47600	725	1225	200	270	827	150	M20x30	M42x2	63	115	40	52	25	G 3/4	23	476	55	85
RE 06 SK08	200	20	47600	725	1225	200	325	839	150	M20x30	M42x2	63	115	40	52	25	G 3/4	23	534	55	154
RE 06 SK08	300	10	47600	725	1225	200	270	927	150	M20x30	M42x2	63	115	40	52	25	G 3/4	23	476	55	85
RE 06 SK08	300	20	47600	725	1225	200	325	909	150	M20x30	M42x2	63	115	40	52	25	G 3/4	23	534	55	154

Max. power indication ± 5%

PowerPak – "S" Series

10 bar – 0.7 to 100 t

SPECIFICATIONS

Overall Stroke: 50 to 400 mm
Power Stroke: 6 to 80 mm
Power: 0.7 to 100 t
Operating Pressure: 2 to 10 bar. Maximum power is achieved at 10 bar operating pressure.
Customized Design: on request.
Power Stroke Limitation: on request.

Model Number (Example)

RE 10 S01 - 100 - 10

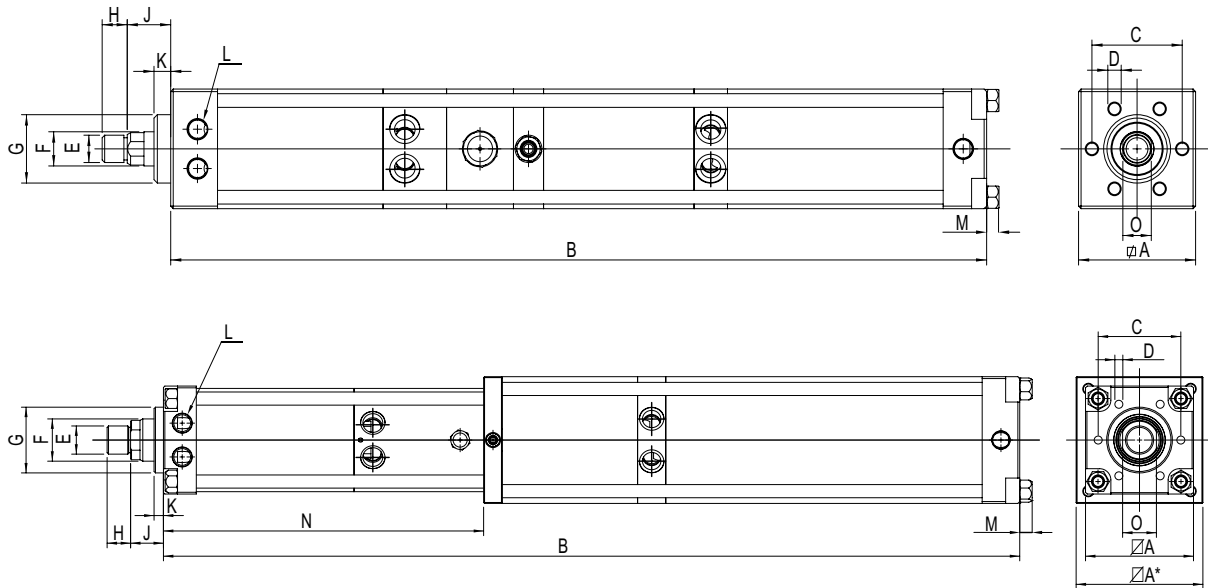
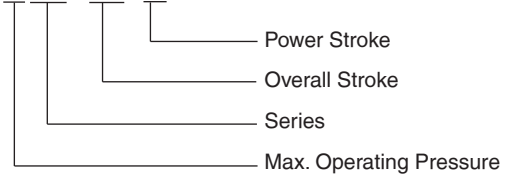

Type	Overall Stroke mm	Power Stroke mm	max. Power (daN)	Power, Fast Str. (daN)	Power, Return Str. (daN)	Dimensions mm													
						A	A*	B	C	D (6x)	E	F	G	H	J	K	L	M	N
RE 10 S01	50	6	700	95	100	50		413	40	M6x12	M12x1,5	16	30	12	24	10	G 1/8		14
RE 10 S01	50	12	1050	95	100	60		453	40	M6x12	M12x1,5	16	30	12	24	10	G 1/8		14
RE 10 S01	100	6	700	95	100	50		553	40	M6x12	M12x1,5	16	30	12	24	10	G 1/8		14
RE 10 S01	100	12	1050	95	100	60		579	40	M6x12	M12x1,5	16	30	12	24	10	G 1/8		14
RE 10 S02	50	6	1210	144	166	60		480	40	M6x12	M12x1,5	16	30	12	24	10	G 1/8		14
RE 10 S02	50	12	1325	144	166	70		477	40	M6x12	M12x1,5	16	30	12	24	10	G 1/8		14
RE 10 S02	100	6	1210	144	166	60		626	40	M6x12	M12x1,5	16	30	12	24	10	G 1/8		14
RE 10 S02	100	12	1325	144	166	60		607	40	M6x12	M12x1,5	16	30	12	24	10	G 1/8		14
RE 10 S02	150	6	1210	144	166	60		772	40	M6x12	M12x1,5	16	30	12	24	10	G 1/8		14
RE 10 S02	150	12	1325	144	166	60		737	40	M6x12	M12x1,5	16	30	12	24	10	G 1/8		14
RE 10 S03	50	6	2100	250	265	70		468	54	M8x12	M16x1,5	20	40	15	26	10	G 1/4		17
RE 10 S03	50	12	2100	250	265	70		505	54	M8x12	M16x1,5	20	40	15	26	10	G 1/4		17
RE 10 S03	50	25	2070	250	265	70	85	564	54	M8x12	M16x1,5	20	40	15	26	10	G 1/4	205	17
RE 10 S03	100	6	2100	250	265	70		600	54	M8x12	M16x1,5	20	40	15	26	10	G 1/4		17
RE 10 S03	100	12	2100	250	265	70		637	54	M8x12	M16x1,5	20	40	15	26	10	G 1/4		17
RE 10 S03	100	25	2070	250	265	70	85	686	54	M8x12	M16x1,5	20	40	15	26	10	G 1/4	305	17
RE 10 S03	100	40	2070	250	265	70	85	751	54	M8x12	M16x1,5	20	40	15	26	10	G 1/4	305	17
RE 10 S03	100	60	2070	250	265	70	110	733	54	M8x12	M16x1,5	20	40	15	26	10	G 1/4	305	17
RE 10 S03	150	6	2100	250	265	70		732	54	M8x12	M16x1,5	20	40	15	26	10	G 1/4		17
RE 10 S03	150	12	2100	250	265	70		769	54	M8x12	M16x1,5	20	40	15	26	10	G 1/4		17
RE 10 S03	150	25	2070	250	265	70	85	808	54	M8x12	M16x1,5	20	40	15	26	10	G 1/4	405	17
RE 10 S03	150	40	2070	250	265	70	85	873	54	M8x12	M16x1,5	20	40	15	26	10	G 1/4	405	17
RE 10 S03	150	60	2070	250	265	70	110	845	54	M8x12	M16x1,5	20	40	15	26	10	G 1/4	405	17
RE 10 S03	150	80	2070	250	265	70	110	894	54	M8x12	M16x1,5	20	40	15	26	10	G 1/4	405	17

Max. power indication ± 5%

PowerPak – "S" Series

10 bar – 0.7 to 100 t

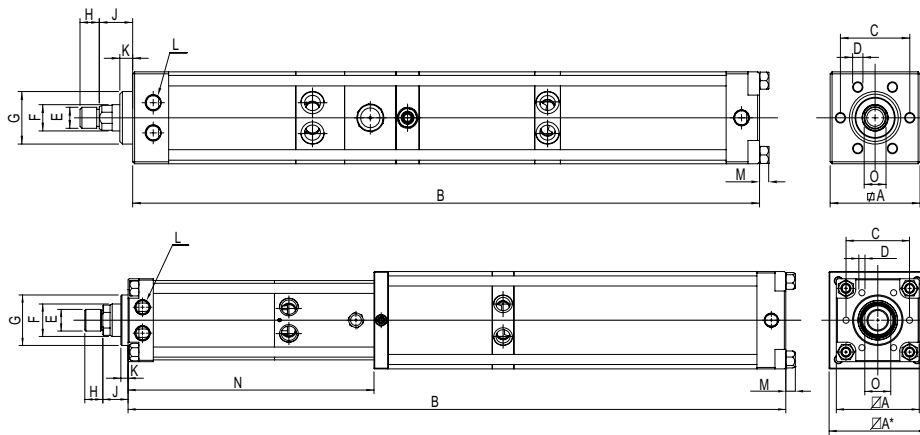

Type	Overall Stroke mm	Power Stroke mm	max. Power (daN)	Power, Fast Str. (daN)	Power, Return Str. (daN)	Dimensions mm														
						A	A*	B	C	D (6x)	E	F	G	H	J	K	L	M	N	O
RE 10 S03	200	6	2100	250	265	70		864	54	M8x12	M16x1,5	20	40	15	26	10	G 1/4		17	
RE 10 S03	200	12	2100	250	265	70		901	54	M8x12	M16x1,5	20	40	15	26	10	G 1/4		17	
RE 10 S03	200	25	2070	250	265	70	85	930	54	M8x12	M16x1,5	20	40	15	26	10	G 1/4		505 17	
RE 10 S03	200	40	2070	250	265	70	85	995	54	M8x12	M16x1,5	20	40	15	26	10	G 1/4		505 17	
RE 10 S03	200	60	2070	250	265	70	110	957	54	M8x12	M16x1,5	20	40	15	26	10	G 1/4		505 17	
RE 10 S03	200	80	2070	250	265	70	110	1006	54	M8x12	M16x1,5	20	40	15	26	10	G 1/4		505 17	
RE 10 S03	250	40	2070	250	265	70	85	1119	54	M8x12	M16x1,5	20	40	15	26	10	G 1/4		605 17	
RE 10 S03	250	80	2070	250	265	70	110	1118	54	M8x12	M16x1,5	20	40	15	26	10	G 1/4		605 17	
RE 10 S04	50	6	4100	320	340	85		539	64	M8x15	M22x2	30	50	20	28,5	10	G 3/8		24	
RE 10 S04	50	12	4100	320	340	85		593	64	M8x15	M22x2	30	50	20	28,5	10	G 3/8		24	
RE 10 S04	70	25	4100	320	340	90	110	669	64	M8x15	M22x2	30	50	20	28,5	10	G 3/8		251 24	
RE 10 S04	100	6	4100	320	340	85		685	64	M8x15	M22x2	30	50	20	28,5	10	G 3/8		24	
RE 10 S04	100	12	4100	320	340	85		739	64	M8x15	M22x2	30	50	20	28,5	10	G 3/8		24	
RE 10 S04	100	25	4100	320	340	90	110	745	64	M8x15	M22x2	30	50	20	28,5	10	G 3/8		311 24	
RE 10 S04	100	40	4100	320	340	90	135	736	64	M8x15	M22x2	30	50	20	28,5	10	G 3/8		311 24	
RE 10 S04	150	6	4100	320	340	85		831	64	M8x15	M22x2	30	50	20	28,5	10	G 3/8		24	
RE 10 S04	150	12	4100	320	340	85		885	64	M8x15	M22x2	30	50	20	28,5	10	G 3/8		24	
RE 10 S04	150	25	4100	320	340	90	110	871	64	M8x15	M22x2	30	50	20	28,5	10	G 3/8		411 24	
RE 10 S04	150	40	4100	320	340	90	135	853	64	M8x15	M22x2	30	50	20	28,5	10	G 3/8		411 24	
RE 10 S04	200	6	4100	320	340	85		977	64	M8x15	M22x2	30	50	20	28,5	10	G 3/8		24	
RE 10 S04	200	12	4100	320	340	85		1031	64	M8x15	M22x2	30	50	20	28,5	10	G 3/8		24	
RE 10 S04	200	25	4100	320	340	90	110	997	64	M8x15	M22x2	30	50	20	28,5	10	G 3/8		511 24	
RE 10 S04	200	40	4100	320	340	90	135	969	64	M8x15	M22x2	30	50	20	28,5	10	G 3/8		511 24	
RE 10 S04	200	50	4100	320	340	90	135	1034	64	M8x15	M22x2	30	50	20	28,5	10	G 3/8		511 24	
RE 10 S04	250	12	4100	320	340	85		1177	64	M8x15	M22x2	30	50	20	28,5	10	G 3/8		24	
RE 10 S04	250	25	4100	320	340	90	110	1123	64	M8x15	M22x2	30	50	20	28,5	10	G 3/8		611 24	
RE 10 S04	300	60	4100	320	340	90	135	1268	64	M8x15	M22x2	30	50	20	28,5	10	G 3/8		711 24	
RE 10 S04	400	60	4100	320	340	90	135	1502	64	M8x15	M22x2	30	50	20	28,5	10	G 3/8		911 24	
RE 10 S05	50	6	7840	560	595	110		605	88	M10x16	M30x2	45	70	25	35	10	G 1/2		36	
RE 10 S05	50	12	7840	560	595	110		664	88	M10x16	M30x2	45	70	25	35	10	G 1/2		36	
RE 10 S05	50	25	7840	560	595	115	135	692	88	M10x16	M30x2	45	70	25	35	10	G 1/2		241 36	
RE 10 S05	100	6	7840	560	595	110		755	88	M10x16	M30x2	45	70	25	35	10	G 1/2		36	
RE 10 S05	100	12	7840	560	595	110		814	88	M10x16	M30x2	45	70	25	35	10	G 1/2		36	
RE 10 S05	100	25	7840	560	595	115	135	824	88	M10x16	M30x2	45	70	25	35	10	G 1/2		341 36	
RE 10 S05	100	40	8200	560	595	115	170	855	88	M10x16	M30x2	45	70	25	35	10	G 1/2		341 36	
RE 10 S05	150	6	7840	560	595	110		905	88	M10x16	M30x2	45	70	25	35	10	G 1/2		36	
RE 10 S05	150	12	7840	560	595	110		964	88	M10x16	M30x2	45	70	25	35	10	G 1/2		36	
RE 10 S05	150	25	7840	560	595	115	135	956	88	M10x16	M30x2	45	70	25	35	10	G 1/2		441 36	
RE 10 S05	150	40	8200	560	595	115	170	975	88	M10x16	M30x2	45	70	25	35	10	G 1/2	17	441 36	
RE 10 S05	200	6	7840	560	595	110		1055	88	M10x16	M30x2	45	70	25	35	10	G 1/2		36	

Max. power indication ± 5%

PowerPak – "S"-Series

10 bar – 0.7 to 100 t

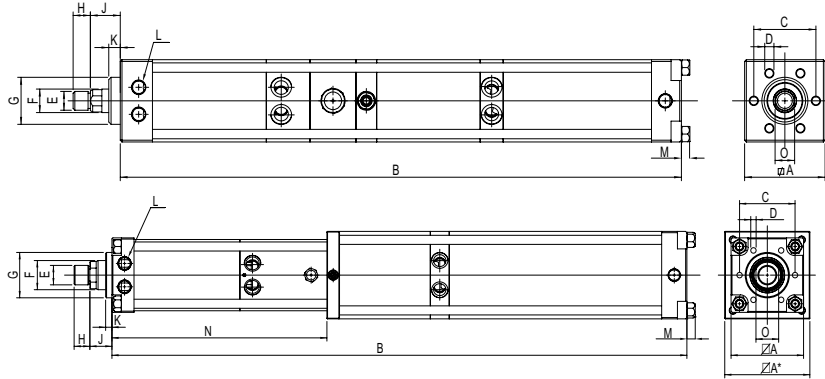

Type	Overall Stroke mm	Power Stroke mm	max. Power (daN)	Power, Fast Str. (daN)	Power, Return Str. (daN)	Dimensions mm													
						A	A*	B	C	D (6x)	E	F	G	H	J	K	L	M	N
RE 10 S05	200	12	7840	560	595	110		1114	88	M10x16	M30x2	45	70	25	35	10	G 1/2		36
RE 10 S05	200	25	7840	560	595	115	135	1088	88	M10x16	M30x2	45	70	25	35	10	G 1/2	13	541 36
RE 10 S05	200	40	8200	560	595	115	170	1095	88	M10x16	M30x2	45	70	25	35	10	G 1/2	17	541 36
RE 10 S05	200	60	8200	560	595	115	170	1175	88	M10x16	M30x2	45	70	25	35	10	G 1/2	17	541 36
RE 10 S05	250	12	7840	560	595	110		1264	88	M10x16	M30x2	45	70	25	35	10	G 1/2		36
RE 10 S05	250	25	7840	560	595	115	135	1220	88	M10x16	M30x2	45	70	25	35	10	G 1/2	13	641 36
RE 10 S05	250	40	8200	560	595	115	170	1215	88	M10x16	M30x2	45	70	25	35	10	G 1/2	17	641 36
RE 10 S05	300	60	8200	560	595	115	170	1415	88	M10x16	M30x2	45	70	25	35	10	G 1/2	17	741 36
RE 10 S05	400	60	8200	560	595	115	170	1655	88	M10x16	M30x2	45	70	25	35	10	G 1/2	17	941 36
RE 10 S06	50	6	15000	800	975	135		652	100	M16x25	M30x2	50	75	25	36	15	G 1/2	17	41
RE 10 S06	50	12	15000	800	975	135		724	100	M16x25	M30x2	50	75	25	36	15	G 1/2	17	41
RE 10 S06	100	6	15000	800	975	135		814	100	M16x25	M30x2	50	75	25	36	15	G 1/2	17	41
RE 10 S06	100	12	15000	800	975	135		887	100	M16x25	M30x2	50	75	25	36	15	G 1/2	17	41
RE 10 S06	100	25	15750	800	975	140	170	943	100	M16x25	M30x2	50	75	25	36	15	G 1/2	17	353 41
RE 10 S06	150	6	15000	800	975	135		977	100	M16x25	M30x2	50	75	25	36	15	G 1/2	17	41
RE 10 S06	150	12	15000	800	975	135		1050	100	M16x25	M30x2	50	75	25	36	15	G 1/2	17	41
RE 10 S06	150	25	15750	800	975	140	170	1081	100	M16x25	M30x2	50	75	25	36	15	G 1/2	17	453 41
RE 10 S06	150	40	15000	800	975	140	200	1116	100	M16x25	M30x2	50	75	25	36	15	G 1/2	17	453 41
RE 10 S06	200	6	15000	800	975	135		1140	100	M16x25	M30x2	50	75	25	36	15	G 1/2	17	41
RE 10 S06	200	12	15000	800	975	135		1213	100	M16x25	M30x2	50	75	25	36	15	G 1/2	17	41
RE 10 S06	200	25	15750	800	975	140	170	1219	100	M16x25	M30x2	50	75	25	36	15	G 1/2	17	553 41
RE 10 S06	200	40	15000	800	975	140	200	1246	100	M16x25	M30x2	50	75	25	36	15	G 1/2	17	553 41
RE 10 S06	250	12	15000	800	975	135		1376	100	M16x25	M30x2	50	75	25	36	15	G 1/2	17	41
RE 10 S06	250	25	15750	800	975	140	170	1357	100	M16x25	M30x2	50	75	25	36	15	G 1/2	17	653 41
RE 10 S06	250	40	15000	800	975	140	200	1376	100	M16x25	M30x2	50	75	25	36	15	G 1/2	17	653 41
RE 10 S06	300	25	15750	800	975	140	170	1495	100	M16x25	M30x2	50	75	25	36	15	G 1/2	17	753 41
RE 10 S06	300	40	15000	800	975	140	200	1506	100	M16x25	M30x2	50	75	25	36	15	G 1/2	17	753 41
RE 10 S07	50	6	31700	1150	1675	170		751	132	M20x30	M39x2	56	100	35	47	18	G 3/4	23	50
RE 10 S07	70	12	31700	1150	1675	170		919	132	M20x30	M39x2	56	100	35	47	18	G 3/4	23	50
RE 10 S07	100	6	31700	1150	1675	170		929	132	M20x30	M39x2	56	100	35	47	18	G 3/4	23	50
RE 10 S07	100	12	31700	1150	1675	170		1025	132	M20x30	M39x2	56	100	35	47	18	G 3/4	23	50
RE 10 S07	100	25	30250	1150	1675	190	270	936	132	M20x30	M39x2	56	100	35	47	18	G 3/4	17	361 50
RE 10 S07	150	6	31700	1150	1675	170		1107	132	M20x30	M39x2	56	100	35	47	18	G 3/4	23	50
RE 10 S07	150	12	31700	1150	1675	170		1203	132	M20x30	M39x2	56	100	35	47	18	G 3/4	23	50
RE 10 S07	150	25	30250	1150	1675	190	270	1068	132	M20x30	M39x2	56	100	35	47	18	G 3/4	17	461 50
RE 10 S07	200	6	31700	1150	1675	170		1285	132	M20x30	M39x2	56	100	35	47	18	G 3/4	23	50
RE 10 S07	200	12	31700	1150	1675	170		1381	132	M20x30	M39x2	56	100	35	47	18	G 3/4	23	50
RE 10 S07	200	25	30250	1150	1675	190	270	1200	132	M20x30	M39x2	56	100	35	47	18	G 3/4	17	561 50
RE 10 S07	200	40	30250	1150	1675	190	270	1293	132	M20x30	M39x2	56	100	35	47	18	G 3/4	17	561 50
RE 10 S07	250	12	31700	1150	1675	170		1559	132	M20x30	M39x2	56	100	35	47	18	G 3/4	23	50
RE 10 S07	300	25	30250	1150	1675	190	270	1464	132	M20x30	M39x2	56	100	35	47	18	G 3/4	17	761 50
RE 10 S07	300	40	30250	1150	1675	190	270	1557	132	M20x30	M39x2	56	100	35	47	18	G 3/4	17	761 50
RE 10 S07	400	40	30250	1150	1675	190	270	1821	132	M20x30	M39x2	56	100	35	47	18	G 3/4	17	961 50

Max. power indication ± 5%

PowerPak – "S" Series

10 bar – 0.7 to 100 t

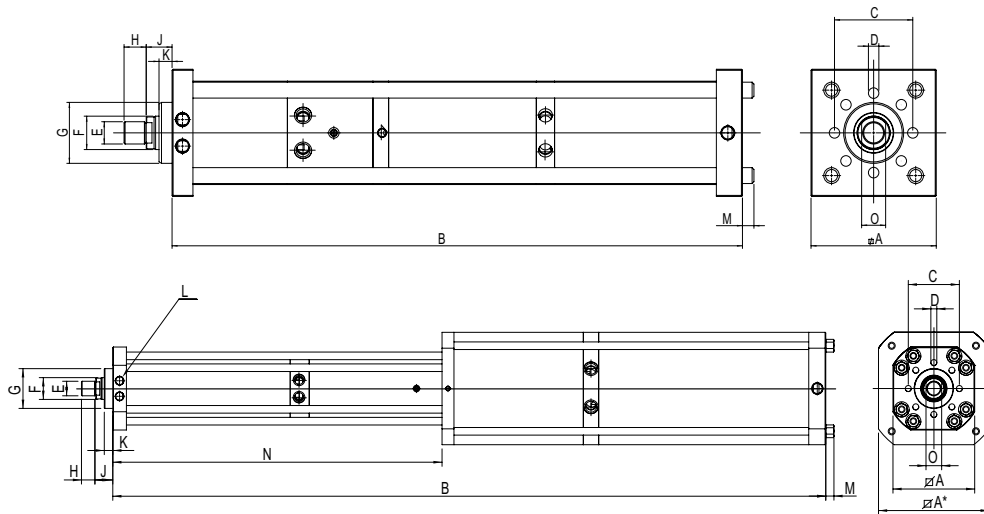

Type	Overall Stroke mm	Power Stroke mm	max. Power (daN)	Power, Fast Str. (daN)	Power, Return Str. (daN)	Dimensions mm														
						A	A*	B	C	D (8x)	E	F	G	H	J	K	L	M	N	O
RE 10 S08	70	6	49400	1250	2120	200		885	150	M20x30	M42x2	63	115	40	52	25	G 3/4	31		55
RE 10 S08	70	12	49400	1250	2120	200		1005	150	M20x30	M42x2	63	115	40	52	25	G 3/4	31		55
RE 10 S08	100	6	49400	1250	2120	200		1003	150	M20x30	M42x2	63	115	40	52	25	G 3/4	31		55
RE 10 S08	100	12	49400	1250	2120	200		1123	150	M20x30	M42x2	63	115	40	52	25	G 3/4	31		55
RE 10 S08	100	25	46800	1250	2120	220	270	1066	150	M20x30	M42x2	63	115	40	52	25	G 3/4	17	367	55
RE 10 S08	150	6	49400	1250	2120	200		1199	150	M20x30	M42x2	63	115	40	52	25	G 3/4	31		55
RE 10 S08	150	12	49400	1250	2120	200		1319	150	M20x30	M42x2	63	115	40	52	25	G 3/4	31		55
RE 10 S08	150	25	46800	1250	2120	220	270	1216	150	M20x30	M42x2	63	115	40	52	25	G 3/4	17	467	55
RE 10 S08	150	40	46800	1250	2120	220	325	1202	150	M20x30	M42x2	63	115	40	52	25	G 3/4	21	467	55
RE 10 S08	200	6	49400	1250	2120	200		1396	150	M20x30	M42x2	63	115	40	52	25	G 3/4	31		55
RE 10 S08	200	12	49400	1250	2120	200		1516	150	M20x30	M42x2	63	115	40	52	25	G 3/4	31		55
RE 10 S08	200	25	46800	1250	2120	220	270	1366	150	M20x30	M42x2	63	115	40	52	25	G 3/4	17	567	55
RE 10 S08	200	40	46800	1250	2120	220	325	1337	150	M20x30	M42x2	63	115	40	52	25	G 3/4	21	567	55
RE 10 S08	300	25	46800	1250	2120	220	270	1666	150	M20x30	M42x2	63	115	40	52	25	G 3/4	17	767	55
RE 10 S08	300	40	46800	1250	2120	220	325	1607	150	M20x30	M42x2	63	115	40	52	25	G 3/4	21	767	55
RE 10 S08	400	40	46800	1250	2120	220	325	1877	150	M20x30	M42x2	63	115	40	52	25	G 3/4	21	967	55

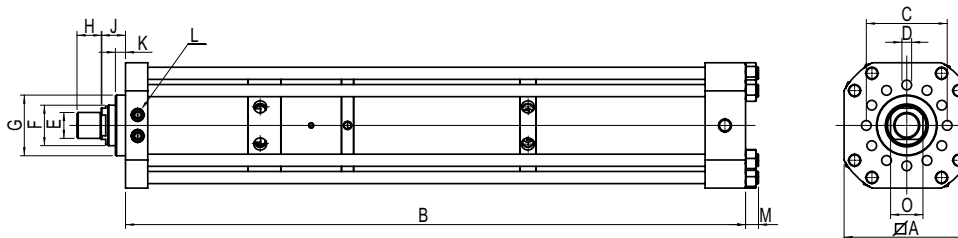

Type	Overall Stroke mm	Power Stroke mm	max. Power (daN)	Power, Fast Str. (daN)	Power, Return Str. (daN)	Dimensions mm														
						A	A*	B	C	D (12x)	E	F	G	H	J	K	L	M	N	O
RE 10 S09	100	15	76800	2240	3900	310		1291	200	M24x40	M64x2	100	150	60	60	25	G 1	31		85
RE 10 S09	150	15	76800	2240	3900	310		1495	200	M24x40	M64x2	100	150	60	60	25	G 1	31		85
RE 10 S09	200	18	76800	2240	3900	310		1760	200	M24x40	M64x2	100	150	60	60	25	G 1	31		85
RE 10 S09	250	25	76800	2240	3900	310		2065	200	M24x40	M64x2	100	150	60	60	25	G 1	31		85
RE 10 S09	300	25	76800	2240	3900	310		2268	200	M24x40	M64x2	100	150	60	60	25	G 1	31		85
RE 10 S10	100	12	96650	2240	3900	310		1291	200	M24x40	M64x2	100	150	60	60	25	G 1	31		85
RE 10 S10	150	15	76800	2240	3900	310		1495	200	M24x40	M64x2	100	150	60	60	25	G 1	31		85
RE 10 S10	200	18	76800	2240	3900	310		1760	200	M24x40	M64x2	100	150	60	60	25	G 1	31		85
RE 10 S10	250	25	76800	2240	3900	310		2065	200	M24x40	M64x2	100	150	60	60	25	G 1	31		85
RE 10 S10	300	25	76800	2240	3900	310		2268	200	M24x40	M64x2	100	150	60	60	25	G 1	31		85

Power Indication ± 5%

PowerPak – "SK" Series

10 bar – 0.7 to 50 t

SPECIFICATIONS

Overall Stroke: 50 to 400 mm
Power Stroke: 5 to 80 mm
Power: 0.7 to 50 t
Operating Pressure: 2 to 10 bar. Maximum power is achieved at 10 bar operating pressure.
Customized Design: on request.
Power Stroke Limitation: on request.

Model Number (Example)

RE 10 SK01 - 100 - 10

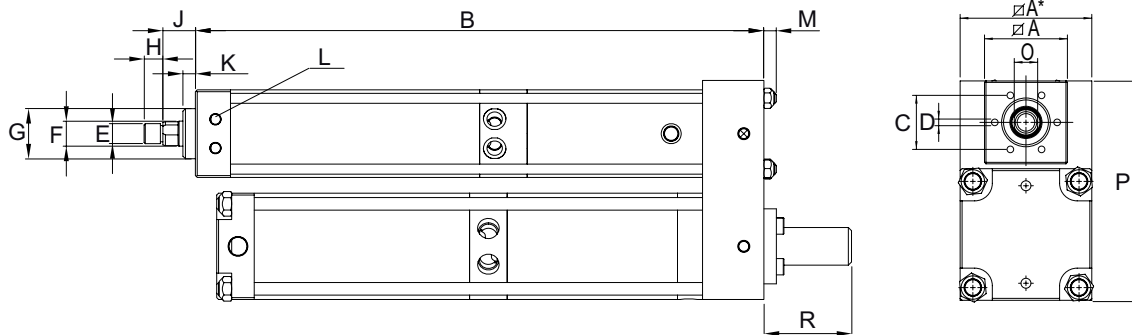
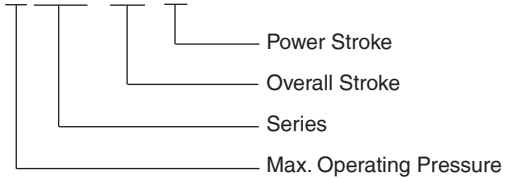

Type	Overall Stroke mm	Power Stroke mm	max. Power (daN)	Power, Fast Str. (daN)	Power, Return Str. (daN)	Dimensions mm														
						A	A*	B	C	D (6x)	E	F	G	H	J	K	L	M	P	O
RE 10 SK01	100	5	700	95	100	50		331	40	M6x12	M12x1,5	16	30	12	24	10	G 1/8	7	105	14
RE 10 SK01	100	10	700	95	100	50	60	321	40	M6x12	M12x1,5	16	30	12	24	10	G 1/8	7	115	14
RE 10 SK01	100	20	1050	95	100	50	70	326	40	M6x12	M12x1,5	16	30	12	24	10	G 1/8	7	125	14
RE 10 SK01	150	5	700	95	100	50		431	40	M6x12	M12x1,5	16	30	12	24	10	G 1/8	7	105	14
RE 10 SK01	150	10	700	95	100	50	60	421	40	M6x12	M12x1,5	16	30	12	24	10	G 1/8	7	115	14
RE 10 SK01	150	20	1050	95	100	50	70	421	40	M6x12	M12x1,5	16	30	12	24	10	G 1/8	7	125	14
RE 10 SK02	100	5	1210	144	167	60		359	40	M6x12	M12x1,5	16	30	12	24	10	G 1/8	9	125	14
RE 10 SK02	100	10	1325	144	167	60	70	347	40	M6x12	M12x1,5	16	30	12	24	10	G 1/8	9	134	14
RE 10 SK02	100	14	1210	144	167	60	85	348	40	M6x12	M12x1,5	16	30	12	24	10	G 1/8	9	150	14
RE 10 SK02	150	5	1210	144	167	60		442	40	M6x12	M12x1,5	16	30	12	24	10	G 1/8	9	125	14
RE 10 SK02	150	11	1325	144	167	60	70	442	40	M6x12	M12x1,5	16	30	12	24	10	G 1/8	9	134	14
RE 10 SK02	150	20	1210	144	167	60	85	442	40	M6x12	M12x1,5	16	30	12	24	10	G 1/8	9	150	14
RE 10 SK03	100	8	2100	250	265	70		369	54	M8x12	M16x1,5	20	40	15	26	10	G 1/4	9	145	17
RE 10 SK03	100	12	2070	250	265	70	85	384	54	M8x12	M16x1,5	20	40	15	26	10	G 1/4	9	160	17
RE 10 SK03	100	20	2070	250	265	70	110	378	54	M8x12	M16x1,5	20	40	15	26	10	G 1/4	9	185	17
RE 10 SK03	150	8	2100	250	265	70		449	54	M8x12	M16x1,5	20	40	15	26	10	G 1/4	9	145	17
RE 10 SK03	150	12	2070	250	265	70	85	449	54	M8x12	M16x1,5	20	40	15	26	10	G 1/4	9	160	17
RE 10 SK03	150	20	2070	250	265	70	110	449	54	M8x12	M16x1,5	20	40	15	26	10	G 1/4	9	185	17
RE 10 SK03	200	8	2100	250	265	70		549	54	M8x12	M16x1,5	20	40	15	26	10	G 1/4	9	145	17
RE 10 SK03	200	12	2070	250	265	70	85	549	54	M8x12	M16x1,5	20	40	15	26	10	G 1/4	9	160	17
RE 10 SK03	200	20	2070	250	265	70	110	549	54	M8x12	M16x1,5	20	40	15	26	10	G 1/4	9	185	17
RE 10 SK04	100	5	4100	320	340	85		419	64	M8x15	M22x2	30	50	20	28,5	10	G 3/8	11	175	24
RE 10 SK04	100	10	4100	320	340	85	110	412	64	M8x15	M22x2	30	50	20	28,5	10	G 3/8	11	200	24
RE 10 SK04	100	20	4100	320	340	85	135	429	64	M8x15	M22x2	30	50	20	28,5	10	G 3/8	11	225	24
RE 10 SK04	150	5	4100	320	340	85		465	64	M8x15	M22x2	30	50	20	28,5	10	G 3/8	11	175	24
RE 10 SK04	150	10	4100	320	340	85	110	460	64	M8x15	M22x2	30	50	20	28,5	10	G 3/8	11	200	24

Max. power indication ± 5%

PowerPak – "SK" Series

10 bar – 0.7 to 50 t

Type	Overall Stroke mm	Power Stroke mm	max. Power (daN)	Power, Fast Str. (daN)	Power, Return Str. (daN)	Dimensions mm															
						A	A*	B	C	D (6x)	E	F	G	H	J	K	L	M	P	O	R
RE 10 SK04	150	20	4100	320	340	85	135	460	64	M8x15	M22x2	30	50	20	28,5	10	G 3/8	11	225	24	
RE 10 SK04	200	5	4100	320	340	85		560	64	M8x15	M22x2	30	50	20	28,5	10	G 3/8	11	175	24	
RE 10 SK04	200	10	4100	320	340	85	110	560	64	M8x15	M22x2	30	50	20	28,5	10	G 3/8	11	200	24	
RE 10 SK04	200	20	4100	320	340	85	135	560	64	M8x15	M22x2	30	50	20	28,5	10	G 3/8	11	225	24	
RE 10 SK05	100	5	7840	560	595	110		467	88	M10x16	M30x2	45	70	25	35	10	G 1/2	13	250	36	
RE 10 SK05	100	10	7840	560	595	110	135	467	88	M10x16	M30x2	45	70	25	35	10	G 1/2	13	250	36	
RE 10 SK05	100	20	8200	560	595	110	170	520	88	M10x16	M30x2	45	70	25	35	10	G 1/2	13	285	36	
RE 10 SK05	150	5	7840	560	595	110		517	88	M10x16	M30x2	45	70	25	35	10	G 1/2	13	225	36	
RE 10 SK05	150	10	7840	560	595	110	135	499	88	M10x16	M30x2	45	70	25	35	10	G 1/2	13	250	36	
RE 10 SK05	150	20	8200	560	595	110	170	540	88	M10x16	M30x2	45	70	25	35	10	G 1/2	13	285	36	
RE 10 SK05	200	5	7840	560	595	110		599	88	M10x16	M30x2	45	70	25	35	10	G 1/2	13	225	36	
RE 10 SK05	200	10	7840	560	595	110	135	599	88	M10x16	M30x2	45	70	25	35	10	G 1/2	13	250	36	
RE 10 SK05	200	20	8200	560	595	110	170	599	88	M10x16	M30x2	45	70	25	35	10	G 1/2	13	285	36	
RE 10 SK05	250	10	7840	560	595	110	135	699	88	M10x16	M30x2	45	70	25	35	10	G 1/2	13	250	36	
RE 10 SK05	250	20	8200	560	595	110	170	699	88	M10x16	M30x2	45	70	25	35	10	G 1/2	13	285	36	
RE 10 SK06	100	5	15000	800	975	135		522	100	M16x25	M30x2	50	75	25	36	15	G 1/2	17	275	41	
RE 10 SK06	100	10	15750	800	975	135	170	557	100	M16x25	M30x2	50	75	25	36	15	G 1/2	17	310	41	
RE 10 SK06	100	20	15000	800	975	135	200	496	100	M16x25	M30x2	50	75	25	36	15	G 1/2	17	336	41	
RE 10 SK06	150	5	15000	800	975	135		585	100	M16x25	M30x2	50	75	25	36	15	G 1/2	17	275	41	
RE 10 SK06	150	10	15750	800	975	135	170	596	100	M16x25	M30x2	50	75	25	36	15	G 1/2	17	310	41	
RE 10 SK06	150	20	15000	800	975	135	200	521	100	M16x25	M30x2	50	75	25	36	15	G 1/2	17	336	41	
RE 10 SK06	200	5	15000	800	975	135		648	100	M16x25	M30x2	50	75	25	36	15	G 1/2	17	275	41	
RE 10 SK06	200	10	15750	800	975	135	170	636	100	M16x25	M30x2	50	75	25	36	15	G 1/2	17	310	41	
RE 10 SK06	200	20	15000	800	975	135	200	621	100	M16x25	M30x2	50	75	25	36	15	G 1/2	17	336	41	
RE 10 SK06	250	5	15000	800	975	135		721	100	M16x25	M30x2	50	75	25	36	15	G 1/2	17	275	41	
RE 10 SK06	250	10	15750	800	975	135	170	721	100	M16x25	M30x2	50	75	25	36	15	G 1/2	17	310	41	
RE 10 SK06	250	20	15000	800	975	135	200	721	100	M16x25	M30x2	50	75	25	36	15	G 1/2	17	336	41	
RE 10 SK07	100	10	30250	1150	1675	170	270	584	132	M20x30	M39x2	56	100	35	47	18	G 3/4	21	446	50	
RE 10 SK07	150	10	30250	1150	1675	170	270	596	132	M20x30	M39x2	56	100	35	47	18	G 3/4	21	446	50	
RE 10 SK07	150	20	30250	1150	1675	170	270	658	132	M20x30	M39x2	56	100	35	47	18	G 3/4	21	446	50	53
RE 10 SK07	200	10	30250	1150	1675	170	270	639	132	M20x30	M39x2	56	100	35	47	18	G 3/4	21	446	50	
RE 10 SK07	200	20	30250	1150	1675	170	270	690	132	M20x30	M39x2	56	100	35	47	18	G 3/4	21	446	50	53
RE 10 SK07	300	20	30250	1150	1675	170	270	839	132	M20x30	M39x2	56	100	35	47	18	G 3/4	21	446	50	53
RE 10 SK07	400	20	30250	1150	1675	170	270	1039	132	M20x30	M39x2	56	100	35	47	18	G 3/4	21	446	50	53

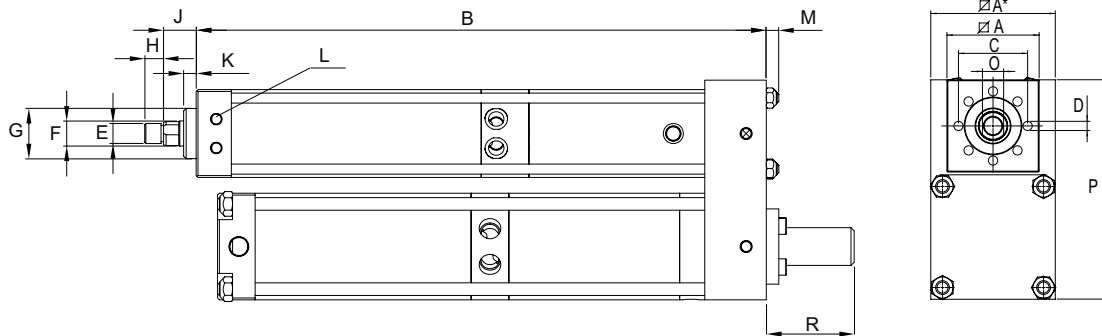

Type	Overall Stroke mm	Power Stroke mm	max. Power (daN)	Power, Fast Str. (daN)	Power, Return Str. (daN)	Dimensions mm															
						A	A*	B	C	D (8x)	E	F	G	H	J	K	L	M	P	O	R
RE 10 SK08	100	10	46800	1250	2120	200	270	665	150	M20x30	M42x2	63	115	40	52	25	G 3/4	23	476	55	
RE 10 SK08	100	20	46800	1250	2120	200	325	709	150	M20x30	M42x2	63	115	40	52	25	G 3/4	23	534	55	42
RE 10 SK08	200	10	46800	1250	2120	200	270	765	150	M20x30	M42x2	63	115	40	52	25	G 3/4	23	476	55	
RE 10 SK08	200	20	46800	1250	2120	200	325	779	150	M20x30	M42x2	63	115	40	52	25	G 3/4	23	534	55	42
RE 10 SK08	300	10	46800	1250	2120	200	270	865	150	M20x30	M42x2	63	115	40	52	25	G 3/4	23	476	55	
RE 10 SK08	300	20	46800	1250	2120	200	325	865	150	M20x30	M42x2	63	115	40	52	25	G 3/4	23	534	55	42

Max. power indication ± 5%



ROSS EUROPA GmbH
Robert-Bosch-Strasse 2
D-63225 Langen/Germany
Tel.: 0049-6103-7597-0
Fax: 0049-6103-74694
e-mail: info@rosseuropa.com
www.rosseuropa.com



ROSS FRANCE S.A.S.
69/73 Boulevard Victor Hugo
Bâtiment 6-8
93400 Saint-Ouen, France
Tel.: 0033-1-49456565
Fax: 0033-1-49456530
e-mail: sales@rossfrance.com
www.rossfrance.com

ROSS UK Ltd.
e-mail: sales@rossuk.co.uk

ROSS CONTROLS®
1250 Stephenson Hwy.
Troy, Michigan 48083 U.S.A.
Tel.: 001-248-764-1800
Fax: 001-248-764-1850
www.rosscontrols.com

ROSS ASIA K.K.
www.rossasia.co.jp

ROSS SOUTH AMERICA Ltda.
e-mail: vendas@ross-sulamerica.com.br

ROSS CONTROLS (CHINA) Ltd.
www.rosscontrolschina.com

ROSS CONTROLS INDIA Pvt. Ltd.
www.rossindia.com

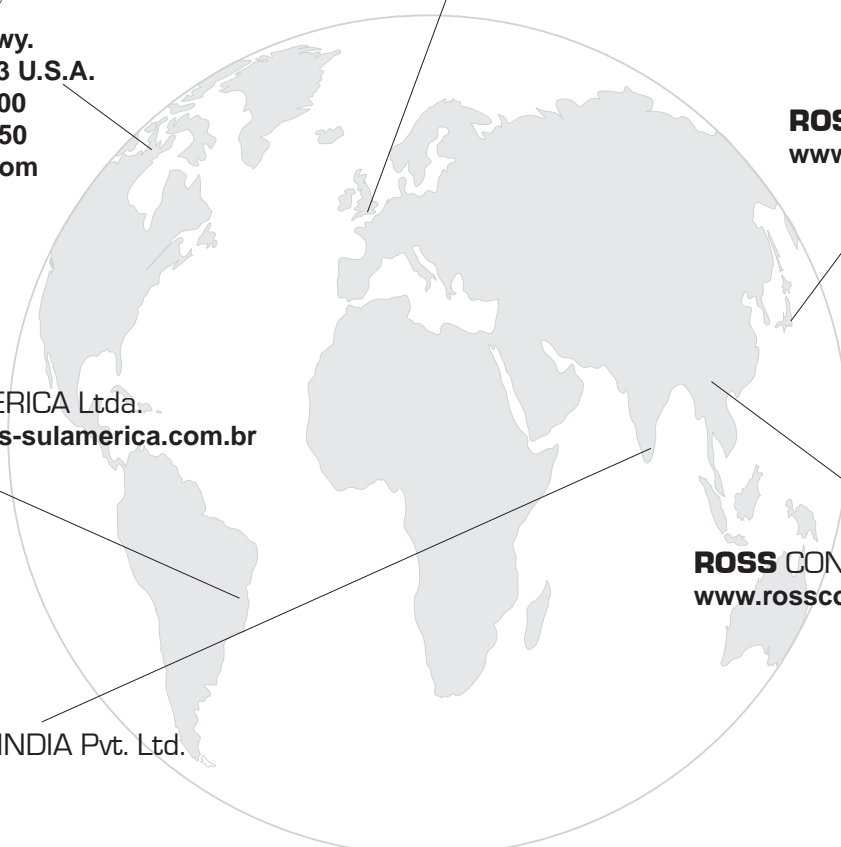

Warranty

Products manufactured by ROSS are warranted to be free of defects in material and workmanship for a period of one year from the date of purchase. ROSS' obligation under this warranty is limited to repair or replacement of the product or refund of the purchase price paid solely at the discretion of ROSS and provided such product is returned to ROSS freight prepaid and upon examination by ROSS such product is found to be defective. This warranty shall be void in the event that product has been subject to misuse, misapplication, improper maintenance, modification or tampering. THE WARRANTY EXPRESSED ABOVE IS IN LIEU OF AND EXCLUSIVE OF ALL OTHER WARRANTIES AND ROSS EXPRESSLY DISCLAIMS ALL OTHER WARRANTIES EITHER EXPRESSED OR IMPLIED WITH RESPECT TO MERCHANTABILITY OR FITNESS FOR A PARTICULAR PURPOSE. ROSS MAKES NO WARRANTY WITH RESPECT TO ITS PRODUCTS MEETING THE PROVISIONS OF ANY GOVERNMENTAL OCCUPATIONAL SAFETY AND/OR HEALTH LAWS OR REGULATIONS. IN NO EVENT SHALL ROSS BE LIABLE TO PURCHASER, USER, THEIR EMPLOYEES OR OTHERS FOR INCIDENTAL OR CONSEQUENTIAL DAMAGES WHICH MAY RESULT FROM A BREACH OF THE WARRANTY DESCRIBED ABOVE OR THE USE OR MISUSE OF THE PRODUCTS. NO STATEMENT OF ANY REPRESENTATIVE OR ANY EMPLOYEE OF ROSS SHALL EXTEND THE LIABILITY OF ROSS AS SET FORTH HEREIN.